



# 门机系列减速电机

Barrier & Gate Turnstile Series Gear Motor



## 关于我们 About Us

作为机电传动领域的创新者，我们的目标是为您提供创新而高效的系统解决方案，以满足您的各种需求。

高精度不仅是一个重要的衡量尺度，也表现了我们所有产品与服务的特质。我们拥有在减速电机制造和传动设备领域超过 20 年的专业经验，因此在涉及到传动系统的选型和计算方面，我们的专业知识是毋庸置疑的。关于如何选择及应用减速电机，我们乐于与您分享我们的专业知识。我们的宗旨就是让所有的用户都可从我们专业的顾问服务及出色的技术支持中获得最大的经济效益。

As an innovator in the field of electromechanical transmission, our goal is to provide you with innovative and efficient system solutions to meet your various needs.

High precision is not only an important measure, but also shows the characteristics of all our products and services. We have more than 20 years of professional experience in the field of geared motor manufacturing and transmission equipment, so our expertise is beyond doubt when it comes to the selection and calculation of transmission systems. Regarding how to choose and apply geared motors, we are happy to share our expertise with you.

Our aim is to allow all users to obtain the greatest economic benefits from our professional consulting services and excellent technical support.

### 我们的服务 Our service

#### 售前服务 Pre-sale Service

- 我们为您的决策铺平道路
- 需求分析
  - 负荷测试
  - 模拟和测试

We pave the way for your decision

- Demand analysis
- Load test
- Simulation and testing

#### 实施过程 Implementation Process

- 我们愿与您一同找出合适的解决方案
- 安装、整合
  - 专业指导
  - 认证

We work with you to find the right solution

- Installation, integration
- Professional guidance
- Certification

#### 售后服务 After-sales Service

- 我们承担应该负有的责任
- 服务协议
  - 维修
  - 配件管理

We take responsibility

- Service Agreement
- Repair Service
- Accessories Management

### 主要产品

- 行星减速器及行星减速电机
- 交流伺服电机及驱动器
- 微型齿轮减速电机
- 中型齿轮减速电机
- 谐波减速器
- 蜗轮蜗杆减速器及减速电机
- 无刷电机、可逆电机、步进电机
- 准双曲面齿轮（直交轴）减速电机
- 电动滚筒电机
- 断路器、高压开关及其它电力设备专用电机等

### Main Products

- Planetary reducer and planetary reducer motor
- AC Servo Motor and Driver
- Micro Gear Motor motor
- Medium Gear Motor motor
- Harmonic reducer
- Worm Gear Motor and reduction motor
- Brushless motor, reversible motor, stepper motor
- Hypoid gear (rectangular axis) geared motor
- Electric drum motor
- Circuit breakers, high voltage switches and other special motors for power equipment, etc.

## 索引 Content

### 广告小门 / 人行通道专用电机

#### Advertising Small Door/Passage Gear Motor

- 方型有刷直流减速电机  
Square Type Brush DC Gear Motor
- 方型无刷直流减速电机  
Square Type Brushless DC Gear Motor
- L 型无刷直流减速电机  
L Type Brushless DC Gear Motor
- 直角型无刷直流减速电机  
Right Angle Brushless DC Gear Motor
- 低压伺服行星齿减速电机  
Low Pressure Servo Planetary Gear Motor



### 普通道闸专用电机

#### Normal Barrier Application Gear Motor

- 单相交流双减速一体机  
Single Phase AC Gear Motor
- 三相交流双减速一体机  
Three Phase AC Gear Motor
- 无刷直流双减速一体机  
Brushless DC Gear Motor
- 无刷直流平行齿减速电机  
Brushless DC Parallel Gear Motor
- 无刷直行星行齿减速电机  
Brushless DC Planetary Gear Motor



### 广告道闸专用电机

#### Advertising Air Barrier Application Gear Motor

- 单相交流双减速一体机  
Single Phase AC Gear Motor
- 三相交流双减速一体机  
Three Phase AC Gear Motor
- 无刷直流双减速一体机  
Brushless DC Gear Motor
- 无刷直流平行齿减速电机  
Brushless DC Parallel Gear Reduce

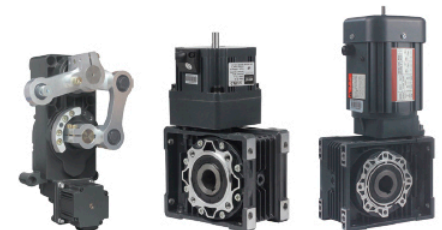

### 空降道闸专用电机

#### Airborne Barrier Application Gear Motor

- 单相交流双减速一体机  
Single Phase AC Gear Motor
- 三相交流双减速一体机  
Three Phase AC Gear Motor



# 门机系列减速电机

## Barrier & Gate Turnstile Series Gear Motor

### 产品概述 Product Overview

门机系列减速电机是电动机与齿轮减速机融为一体的产品，具有结构设计合理，体积小，重量轻，噪音低，运行安全可靠，使用维护方便等特点。

Barrier & Gate Turnstile Series Gear Motor is a product that integrates a motor and a Gear Motor. It has the characteristics of reasonable structure design, small size, light weight, low noise, safe and reliable operation, and convenient use and maintenance.

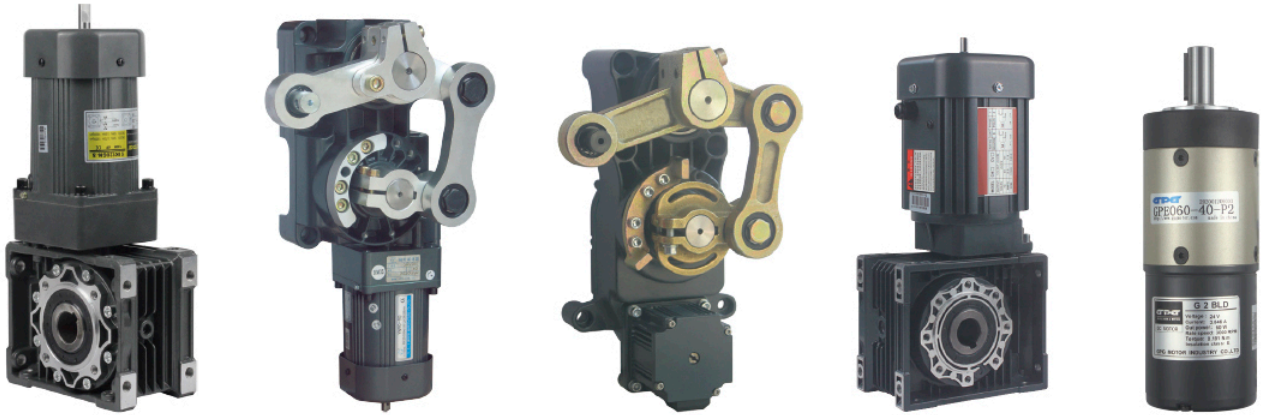

### 产品应用 Application



广告小门 / 人行通道闸  
Advertising Small Door/Passage



普通道闸  
Normal Barrier

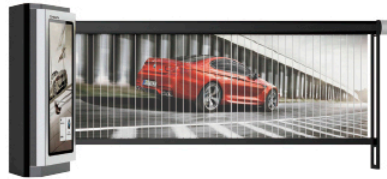

广告道闸  
Advertising Air Barrier

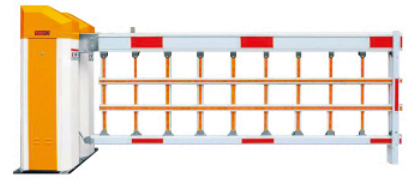

空降道闸  
Airborne Barrier

### 通用技术条件 General Technical Conditions

绝缘耐压强度 Insulation Strength	电机电压 <48: 线圈及机壳以 50Hz, 500V 电压加入 1 分钟无异常 Motor voltage <48; the coil and case are applied at 50Hz, 500V for 1 minute without abnormal 电机电压 >48: 线圈及机壳以 50Hz, 1500V 电压加入 1 分钟无异常 Motor voltage >48: the coil and case are at 50Hz, 1500V Voltage is added for 1 minute without exception
绝缘等级 Insulation Class	E 种 (120°C) Type E (120°C)
工作时间 Operating Time	S2=1min 短时间断续工作制, 门机系列减速电机均采用 S2 工作制 S2=1min when working for a short time, the door machine series geared motors all adopt S2 work system S1 长时间连续工作制 S1 when working for a long time
环境温度 Ambient Temperature	-20°C~+60°C
使用温度 Operating Temperature	85% 不结露状态 85% non-condensing state
绝缘电阻 Insulation Resistance	>50MΩ
防护等级 Protection Level	IP44

## 方型有刷直流减速电机 Square Type Brush DC Gear Motor

### 特点和适用范围 Features and Scope of Application

有刷电机 24V 安全电机，性价比高，电机效率高，可采用电瓶驱动，主要适用于广告小门，人行通道闸。

Brush motor 24V safety motor, high cost performance, high efficiency of the motor, battery drive, mainly suitable for advertising door, pedestrian passage gate.



### 电机接线图 Motor Wiring Diagram

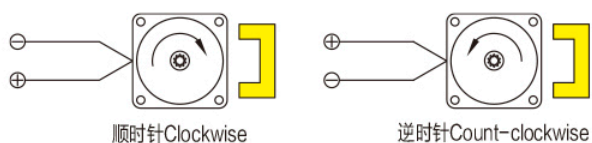

### 减速电机基本性能参数 Basic Performance Parameters for Gear Motor

减速电机型号 Motor Item No.	额定功率 Rated Power (W)	额定电压 Rated Voltage (V)	额定电流 Rated Current (A)	额定转速 Rated Speed (rpm)	减速比 Ratio	输出扭矩 Output Torque (N.m)	传动效率 Transmission Efficiency
GDM55/75-30-24-21S/3GN60KG10L	30	DC24	2.0	2100	60	5.7	73%

### 减速电机尺寸图 External Dimension

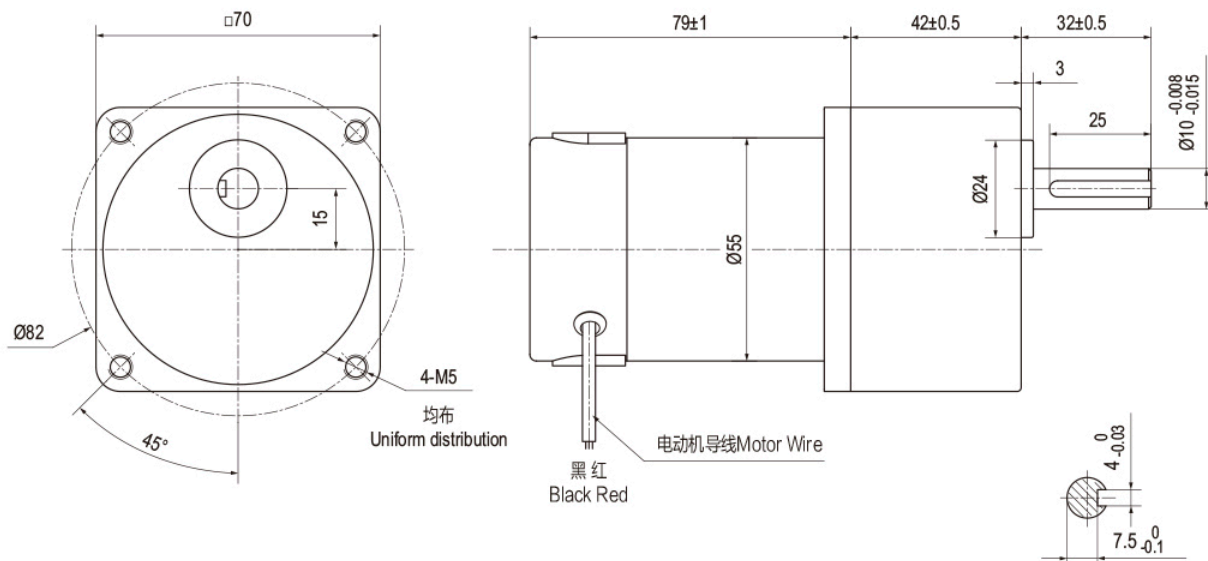

### 方型无刷直流减速电机 Square Type Brushless DC Gear Motor

#### ■ 特点和应用范围 Features and Scope of Application

无刷电机 24V 安全电机，速度可调，启停平稳，电机效率高，可采用电瓶驱动，主要适用于广告小门，人行通道闸。

Brushless motor 24V safety motor, adjustable speed, stable start and stop, high efficiency of the motor, battery drive, mainly suitable for advertising door, pedestrian passage gate.

#### ■ 无刷直流电机接线 Brushless DC Gear Motor Wiring

端子及接线说明 Terminal and Wiring Instructions							
1	2	3	4	5	6	7	8
U	V	W	GND	Hv	Hw	Hu	Vcc
黄 (粗) Yellow (Thick)	白 (粗) White (Thick)	蓝 (粗) Blue (Thick)	黑 (细) Black (Thin)	白 (细) White (Thin)	蓝 (细) Blue (Thin)	黄 (细) Yellow (Thin)	红 (细) Red (Thin)



#### ■ 减速电机基本性能参数 Basic Performance Parameters for Gear Motor

减速电机型号 Motor Item No.	额定功率 Rated Power (W)	额定电压 Rated Voltage (V)	额定电流 Rated Current (A)	额定转速 Rated Speed (rpm)	减速比 Ratio	输出扭矩 Output Torque (N.m)	传动效率 Transmission Efficiency
G2BLD30-24-21S/3GN60KG10L	30	DC24	2.0	2100	60	5.7	73%
G2BLD40-24-21S/3GN50KG10L	40	DC24	2.6	2100	50	6.3	73%

#### ■ 减速电机尺寸图 External Dimension

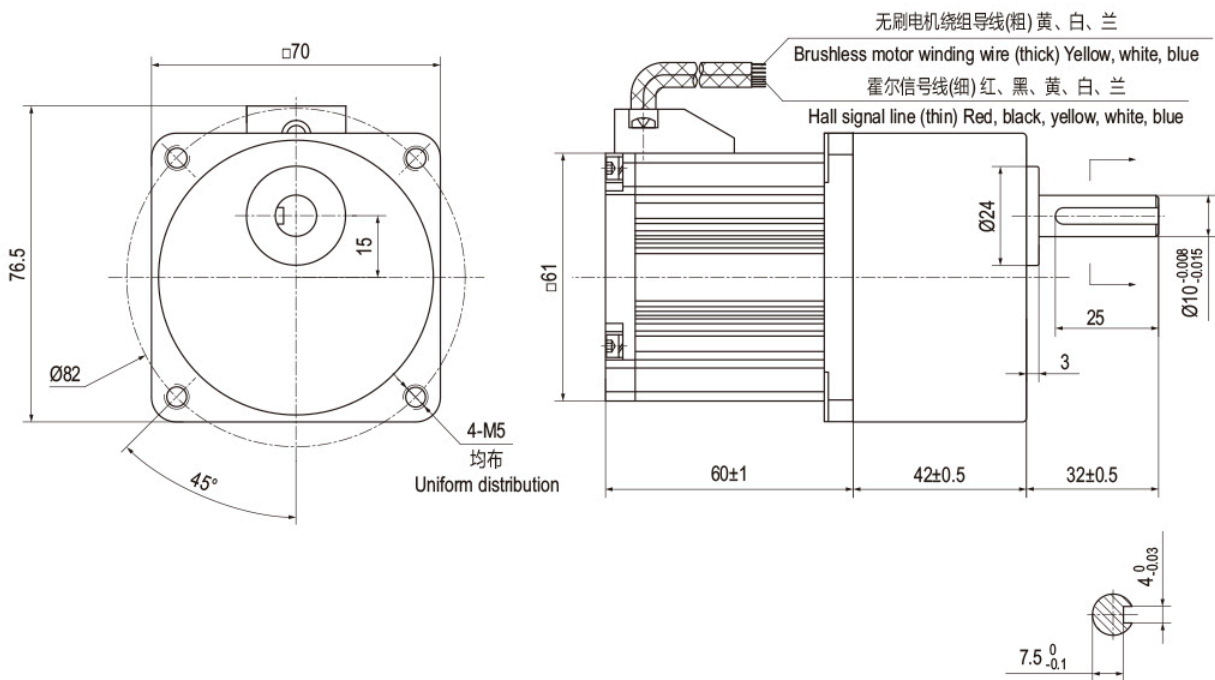

## L 型无刷直流减速电机 L Type Brushless DC Gear Motor

### ■ 特点和应用范围 Features and Scope of Application

无刷电机 24V 安全电机，速度可调，启停平稳，电机效率高，可采用电瓶驱动，主要适用于广告小门，人行通道闸。

Brushless motor 24V safety motor, adjustable speed, stable start and stop, high efficiency of the motor, battery drive, mainly suitable for advertising door, pedestrian passage gate.



### ■ 无刷直流电机接线 Brushless DC Gear Motor Wiring

端子及接线说明 Terminal and Wiring Instructions							
1	2	3	4	5	6	7	8
U	V	W	GND	Hv	Hw	Hu	Vcc
黄 (粗) Yellow (Thick)	白 (粗) White (Thick)	蓝 (粗) Blue (Thick)	黑 (细) Black (Thin)	白 (细) White (Thin)	蓝 (细) Blue (Thin)	黄 (细) Yellow (Thin)	红 (细) Red (Thin)

### ■ 减速电机基本性能参数 Basic Performance Parameters for Gear Motor

减速电机型号 Motor Item No.	额定功率 Rated Power (W)	额定电压 Rated Voltage (V)	额定电流 Rated Current (A)	额定转速 Rated Sped (rpm)	减速比 Ratio	输出扭矩 Output Torque (N.m)	传动效率 Transmission Efficiency
G4BLD40-24-18S/4GFS130S-25	60	DC24	3.6	1800	130	29	73%

### ■ 减速电机尺寸图 External Dimension

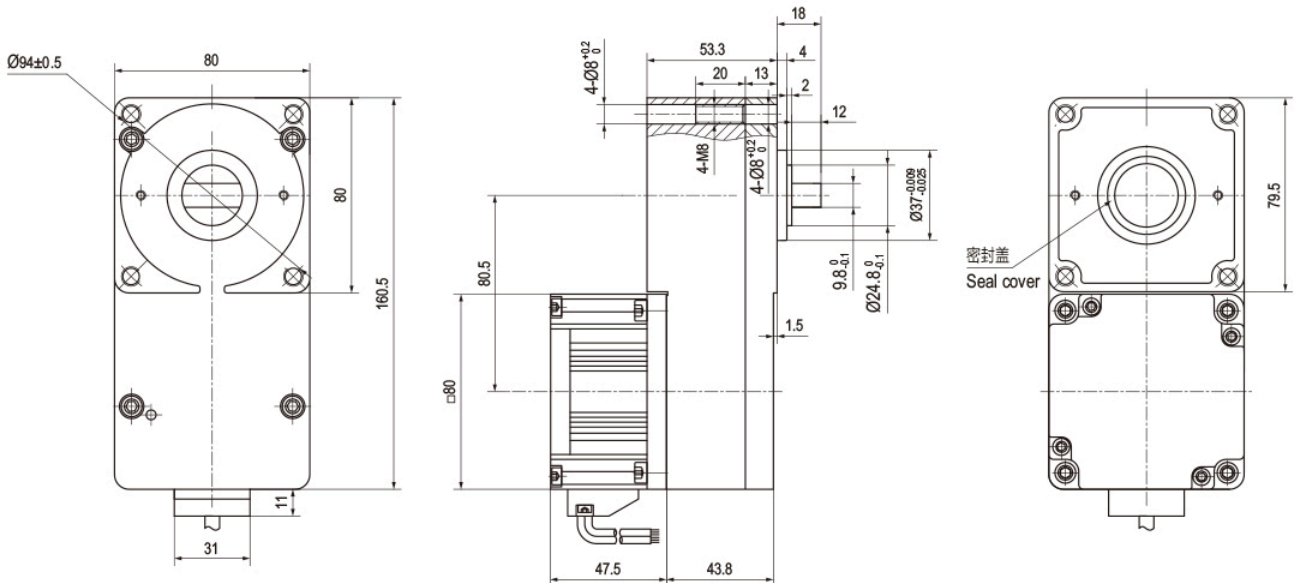

### L 型无刷直流减速电机 L Type Brushless DC Gear Motor

#### ■ 特点和应用范围 Features and Scope of Application

无刷电机 24V 安全电机，速度可调，启停平稳，电机效率高，可采用电瓶驱动，主要适用于广告小门，人行通道闸。

Brushless motor 24V safety motor, adjustable speed, stable start and stop, high efficiency of the motor, battery drive, mainly suitable for advertising door, pedestrian passage gate.

#### ■ 无刷直流电机接线 Brushless DC Gear Motor Wiring

端子及接线说明 Terminal and Wiring Instructions							
1	2	3	4	5	6	7	8
U	V	W	GND	Hv	Hw	Hu	Vcc
黄 (粗) Yellow (Thick)	白 (粗) White (Thick)	蓝 (粗) Blue (Thick)	黑 (细) Black (Thin)	白 (细) White (Thin)	蓝 (细) Blue (Thin)	黄 (细) Yellow (Thin)	红 (细) Red (Thin)



#### ■ 减速电机基本性能参数 Basic Performance Parameters for Gear Motor

减速电机型号 Motor Item No.	额定功率 Rated Power (W)	额定电压 Rated Voltage (V)	额定电流 Rated Current (A)	额定转速 Rated Speed (rpm)	减速比 Ratio	输出扭矩 Output Torque (N.m)	传动效率 Transmission Efficiency
G2BLD40-24-18S/4GFS50S-30	40	DC24	2.3	1800	50	8	73%
G2BLD40-24-18S/4GFS90S-30	40	DC24	2.3	1800	90	14.4	73%

#### ■ 减速电机尺寸图 External Dimension

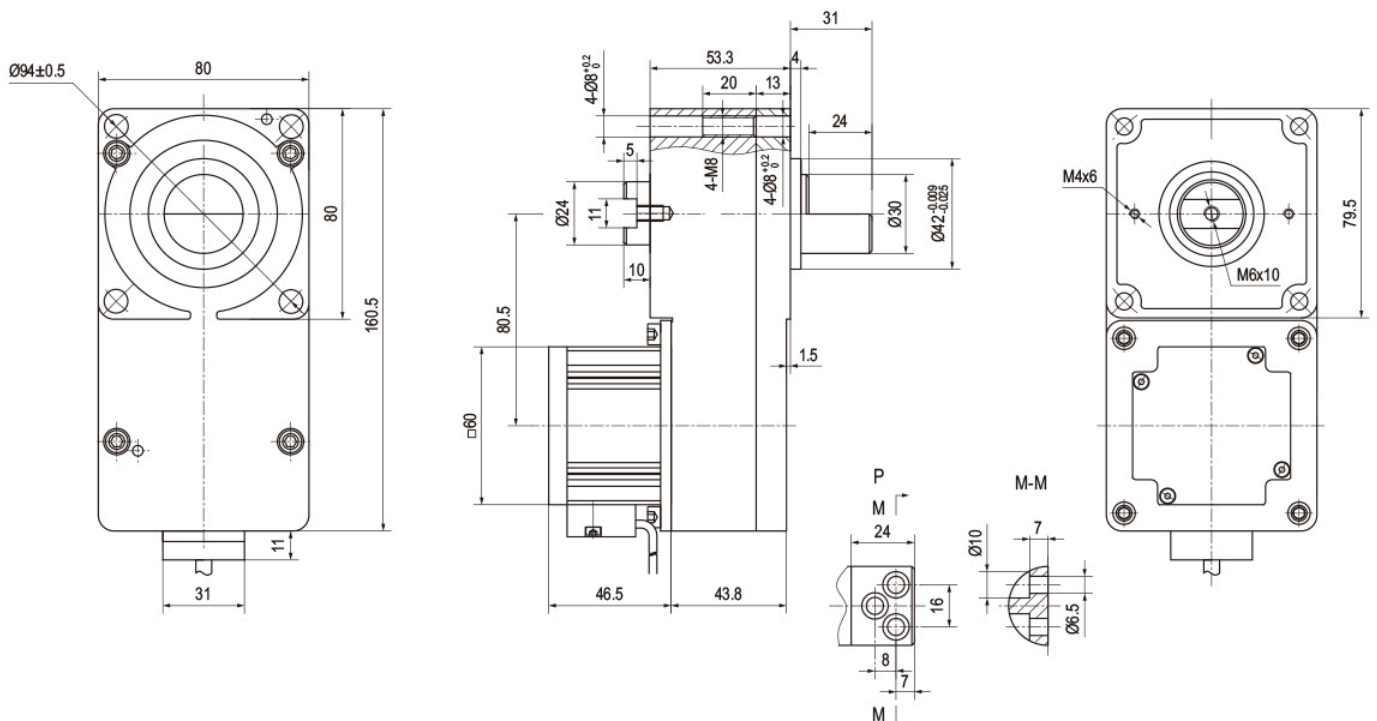



## 直角型无刷直流减速电机 Right Angle Brushless DC Gear Motor

### ■ 特点和应用范围 Features and Scope of Application

无刷电机 24V 安全电机，速度可调，启停平稳，电机效率高，可采用电瓶驱动，直角安装，节约空间，主要适用于速通门，人行通道闸。

Brushless motor 24V safety motor, adjustable speed, stable start and stop, high efficiency of the motor, battery drive, right-angle installation, save space, mainly suitable for speed gates, pedestrian passage gates.



### ■ 无刷直流电机接线 Brushless DC Gear Motor Wiring

端子及接线说明 Terminal and Wiring Instructions							
1	2	3	4	5	6	7	8
U	V	W	GND	Hv	Hw	Hu	Vcc
黄 (粗) Yellow (Thick)	白 (粗) White (Thick)	蓝 (粗) Blue (Thick)	黑 (细) Black (Thin)	白 (细) White (Thin)	蓝 (细) Blue (Thin)	黄 (细) Yellow (Thin)	红 (细) Red (Thin)

### ■ 减速电机基本性能参数 Basic Performance Parameters for Gear Motor

减速电机型号 Motor Item No.	额定功率 Rated Power (W)	额定电压 Rated Voltage (V)	额定电流 Rated Current (A)	额定转速 Rated Sped (rpm)	减速比 Ratio	输出扭矩 Output Torque (N.m)	传动效率 Transmission Efficiency
G2BLD40-24-30S/80GZ50RT-30	40	DC24	2.3	3000	50	4.7	73%

### ■ 减速电机尺寸图 External Dimension

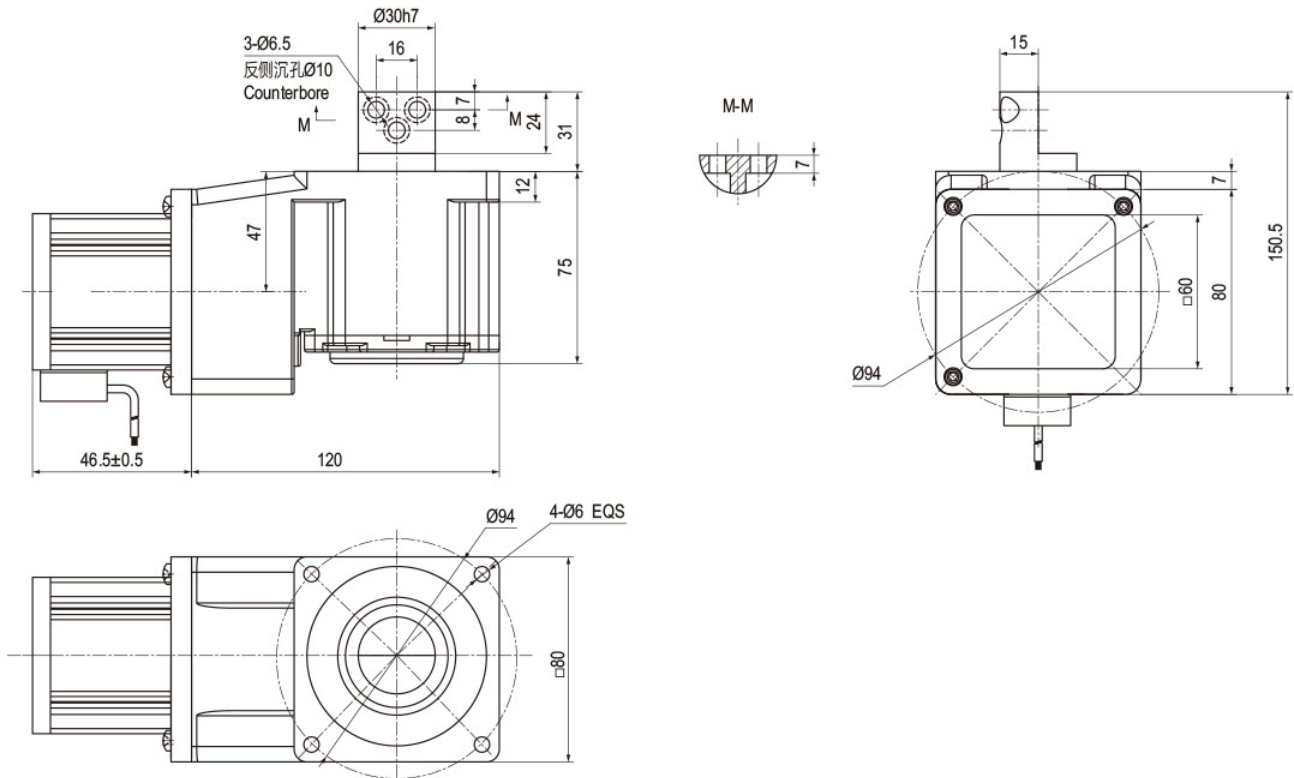

### 低压伺服行星齿减速电机 Low Pressure Servo Planetary Gear Motor

#### ■ 特点和应用范围 Features and Scope of Application

低压伺服电机，机电常数小，线性度高，响应速度快，位置控制精确等特点，主要应用于地铁站、高铁站、海关等速通门领域。

Low-voltage servo motors, with small electromechanical constants, high linearity, fast response speed, precise position control, etc., are mainly used in the fields of subway stations, high-speed railway stations, customs and other high-speed doors.



#### ■ 减速电机基本性能参数 Basic Performance Parameters for Gear Motor

减速电机型号 Motor Item No.	额定功率 Rated Power (W)	额定电压 Rated Voltage (V)	额定电流 Rated Current (A)	额定转速 Rated Speed (rpm)	减速比 Ratio	输出扭矩 Output Torque (N.m)	传动效率 Transmission Efficiency
GSM57/89-100-24-20S06C/GPE060-20	100	DC24	4.0	2000	20	8.6	90%

#### ■ 减速电机尺寸图 External Dimension

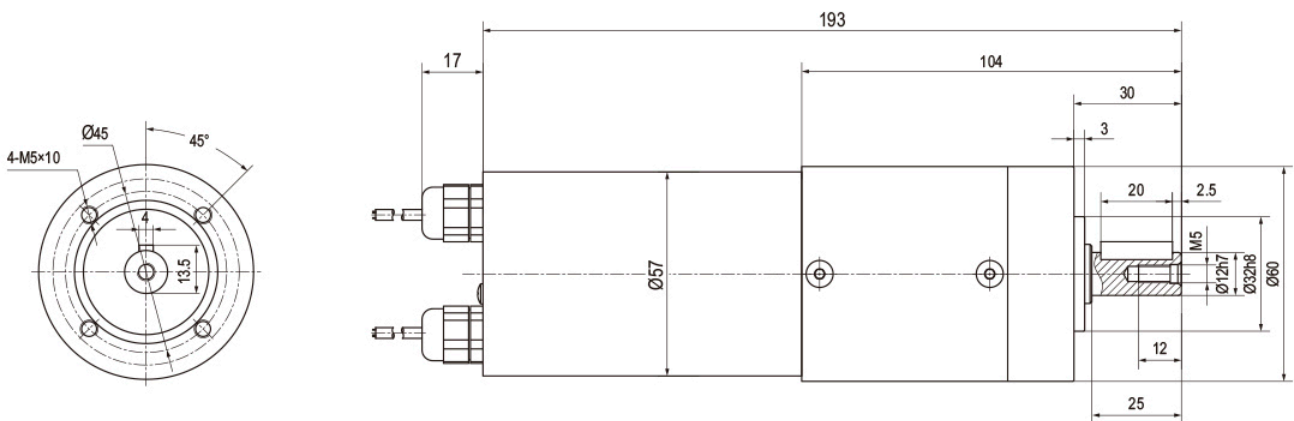

备注：此方案亦可采用无刷直流电机方案。

Remarks: This solution can also use brushless DC motor solution.

## 单相交流双减速一体机 Single Phase AC Gear Motor

### ■ 特点和应用范围 Features and Scope of Application

基础款，性价比高，主要适用于直杆、折弯杆道闸及车牌识别系统道闸。

Basic model, cost-effective, mainly suitable for straight rod, bending rod barrier and license plate recognition system barrier.



### ■ 电机接线图 Motor Wiring Diagram

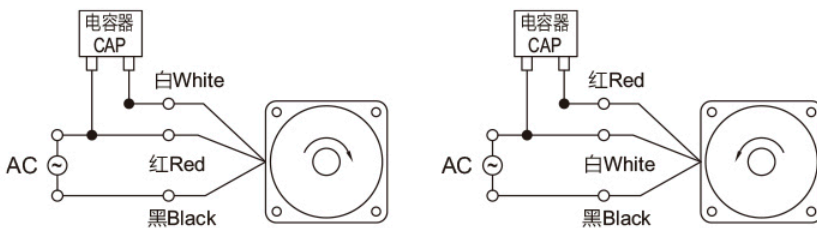

### ■ 减速电机基本性能参数 Basic Performance Parameters for Gear Motor

减速电机型号 Motor Item No.	额定功率 Rated Power (W)	额定频率 Rated Frequency (Hz)	额定电压 Rated Voltage (V)	额定电流 Rated Current (A)	额定转速 Rated Speed (rpm)	电容 Capacitor (μF)	减速比 Ratio	输出扭矩 Output Torque (N.m)	传动效率 Transmission Efficiency	起落杆时间 Lever Time (s)
5RK90CC-F/GRV050UZ-20 × 3.9-90	90	50	单相 Single Phase AC220	1.0	1300	7	78	36	70%	1.5
5RK90CC-F/GRV050UZ-40 × 3.9-90	90	50		1.0	1300	7	156	72	70%	3
5RK90CC-F/GRV050UZ-75 × 3.9-90	90	50		1.0	1300	7	292.5	135	70%	6
5RK120CC-F/GRV050UZ-20 × 3.9-90	120	50		1.2	1300	8	78	36	70%	1.5
5RK120CC-F/GRV050UZ-40 × 3.9-90	120	50		1.2	1300	8	156	72	70%	3
5RK120CC-F/GRV050UZ-75 × 3.9-90	120	50		1.2	1300	8	292.5	135	70%	6

### ■ 减速电机尺寸图 External Dimension

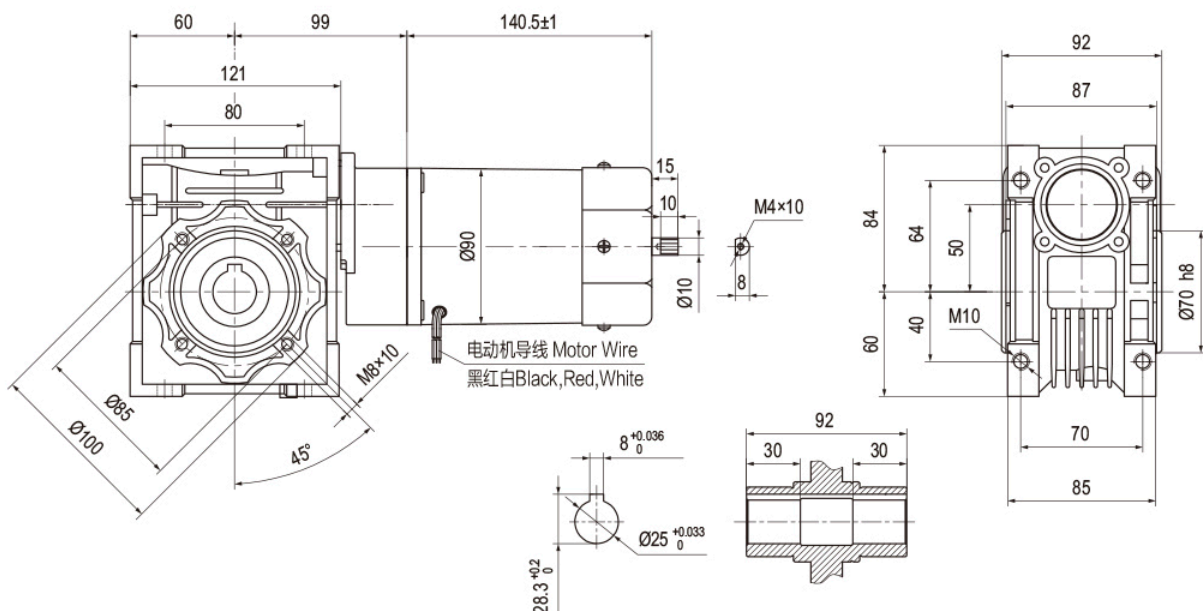

# 普通道闸专用电机

## Normal Barrier Application Gear Motor

### 单相交流双减速一体机 Single Phase AC Gear Motor

#### ■ 特点和应用范围 Features and Scope of Application

减速箱采用专用箱体，预留连杆弹簧机构安装尺寸，一体化设计主要适用于直杆、折弯杆道闸及车牌识别系统道闸。

The gearbox adopts a special box body with a reserved connecting rod spring mechanism installation size. The integrated design is mainly suitable for straight rods, bend rod barriers and license plate recognition system barriers.

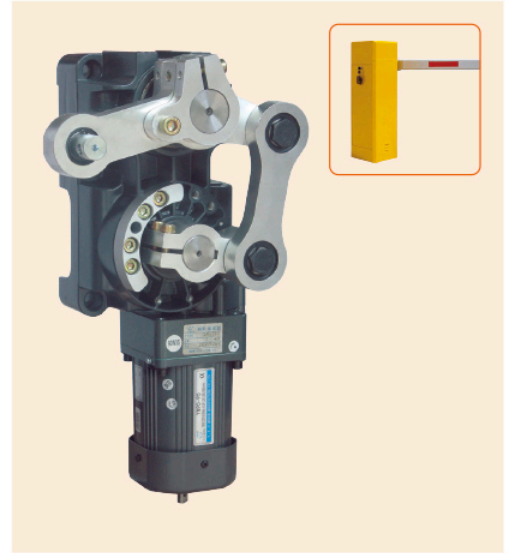

#### ■ 电机接线图 Motor Wiring Diagram

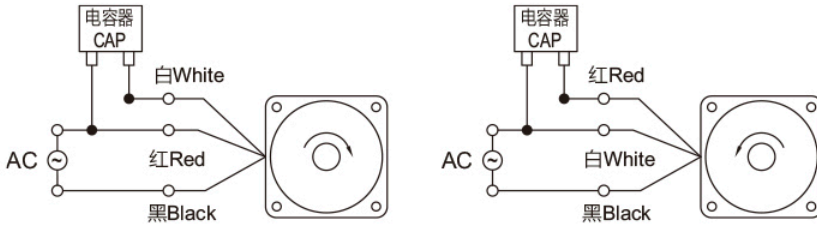

#### ■ 减速电机基本性能参数 Basic Performance Parameters for Gear Motor

减速电机型号 Motor Item No.	额定功率 Rated Power (W)	额定频率 Rated Frequency (Hz)	额定电压 Rated Voltage (V)	额定电流 Rated Current (A)	额定转速 Rated Speed (rpm)	电容 Capacitor (μF)	减速比 Ratio	输出扭矩 Output Torque (N.m)	传动效率 Transmission Efficiency	起落杆时间 Lever Time (s)
5RK90CC-F/MJ50-GRV050UZ-20 × 3.9-90	90	50	单相 Single Phase AC220	1.0	1300	7	78	36	70%	1.5
5RK90CC-F/MJ50-GRV050UZ-40 × 3.9-90	90	50		1.0	1300	7	156	72	70%	3
5RK90CC-F/MJ50-GRV050UZ-75 × 3.9-90	90	50		1.0	1300	7	292.5	135	70%	6
5RK120CC-F/MJ50-GRV050UZ-20 × 3.9-90	120	50		1.2	1300	8	78	36	70%	1.5
5RK120CC-F/MJ50-GRV050UZ-40 × 3.9-90	120	50		1.2	1300	8	156	72	70%	3
5RK120CC-F/MJ50-GRV050UZ-75 × 3.9-90	120	50		1.2	1300	8	292.5	135	70%	6

#### ■ 减速电机尺寸图 External Dimension

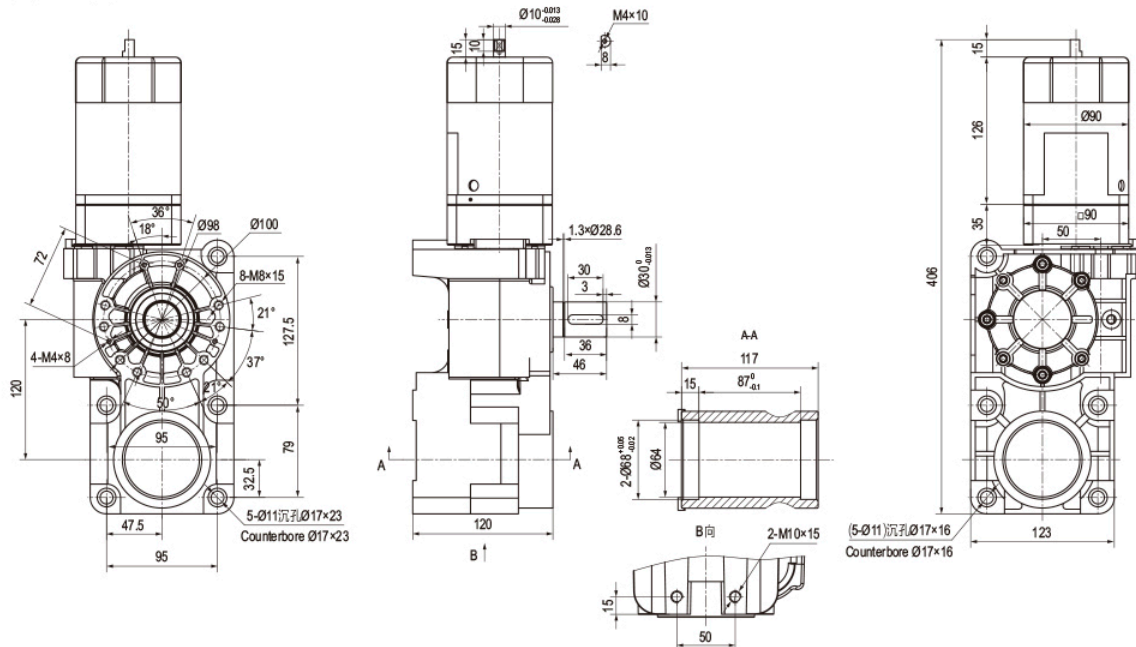

### 三相交流双减速一体机 Three Phase AC Gear Motor

#### ■ 特点和应用范围 Features and Scope of Application

基础款，性价比高，交流变频电机速度可调，启停平稳、对减速箱冲击较小，主要适用于直杆、折弯杆道闸及车牌识别系统道闸。

Basic model, high cost performance, adjustable AC frequency conversion motor speed, stable start and stop, less impact on the gearbox, mainly suitable for straight pole, bend pole barrier and license plate recognition system barrier.

#### ■ 电机接线图 Motor Wiring Diagram

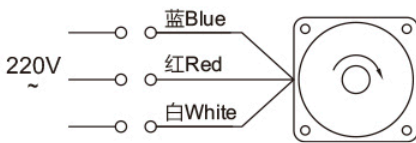

#### ■ 减速电机基本性能参数 Basic Performance Parameters for Gear Motor

减速电机型号 Motor Item No.	额定功率 Rated Power (W)	额定频率 Rated Frequency (Hz)	额定电压 Rated Voltage (V)	额定电流 Rated Current (A)	额定转速 Rated Speed (rpm)	减速比 Ratio	输出扭矩 Output Torque (N.m)	传动效率 Transmission Efficiency	起落杆时间 Lever Time (s)
5RK120SC-F/GRV050UZ-20 × 3.9-90	120	50	三相 Three Phase AC220	0.75	1300	78	36	70%	1.5
5RK120SC-F/GRV050UZ-40 × 3.9-90	120	50		0.75	1300	156	72	70%	3
5RK120SC-F/GRV050UZ-75 × 3.9-90	120	50		0.75	1300	292.5	135	70%	6

#### ■ 减速电机尺寸图 External Dimension

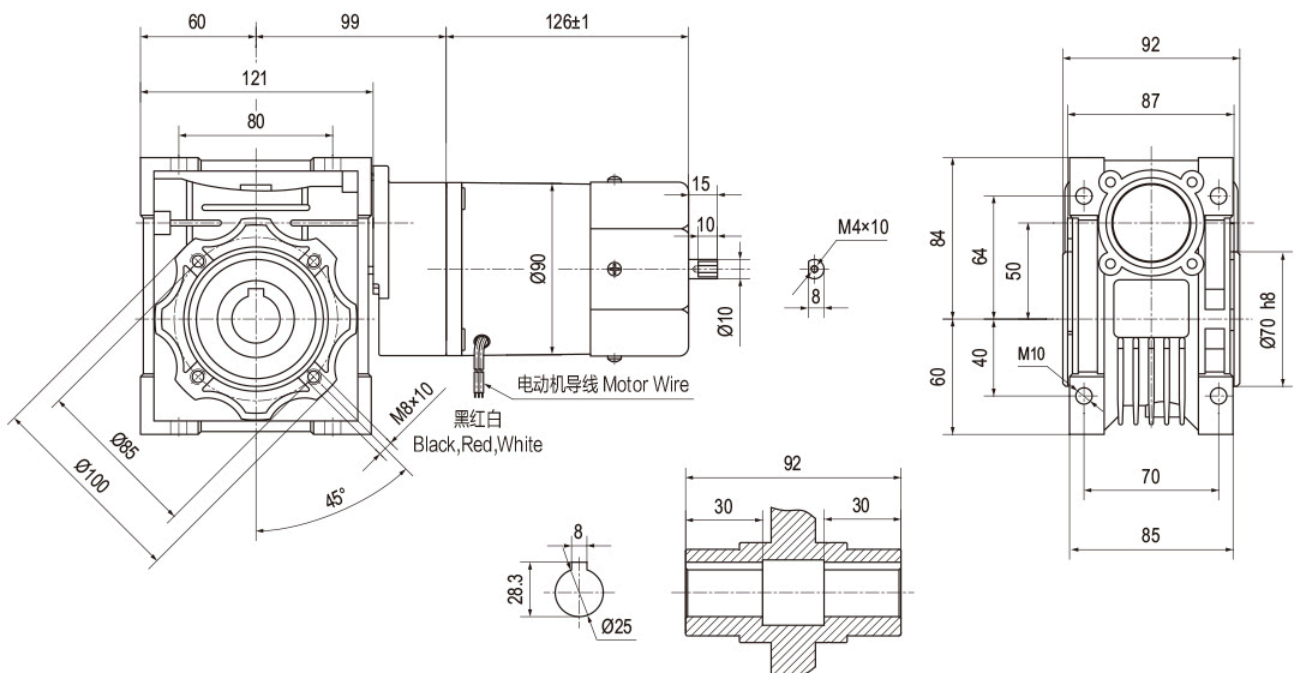

### 三相交流双减速一体机 Three Phase AC Gear Motor

#### ■ 特点和应用范围 Features and Scope of Application

交流变频电机速度可调，启停平稳、对减速箱冲击较小，减速箱采用专用箱体，预留连杆弹簧机构安装尺寸，一体化设计主要适用于直杆、折弯杆道闸及车牌识别系统道闸。

The speed of the AC variable frequency motor is adjustable, the start and stop are stable, and the impact on the gearbox is small. The gearbox adopts a special box body. The installation size of the connecting rod spring mechanism, the integrated design is mainly suitable for straight rod, bending rod barrier and license plate recognition system barrier.

#### ■ 电机接线图 Motor Wiring Diagram

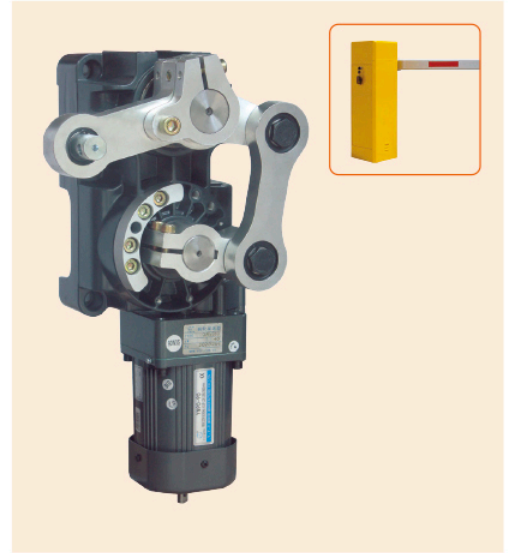
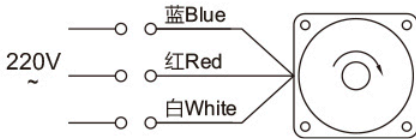

#### ■ 减速电机基本性能参数 Basic Performance Parameters for Gear Motor

减速电机型号 Motor Item No.	额定功率 Rated Power (W)	额定频率 Rated Frequency (Hz)	额定电压 Rated Voltage (V)	额定电流 Rated Current (A)	额定转速 Rated Sped (rpm)	减速比 Ratio	输出扭矩 Output Torque (N.m)	传动效率 Transmission Efficiency	起落杆时间 Lever Time (s)
5RK120SCF/MJ50-GRV050UZ-20 × 3.9-90	120	50	三相 Three Phase AC220	0.75	1300	78	36	70%	1.5
5RK120SCF/MJ50-GRV050UZ-40 × 3.9-90	120	50		0.75	1300	156	72	70%	3
5RK120SCF/MJ50-GRV050UZ-75 × 3.9-90	120	50		0.75	1300	292.5	135	70%	6

#### ■ 减速电机尺寸图 External Dimension

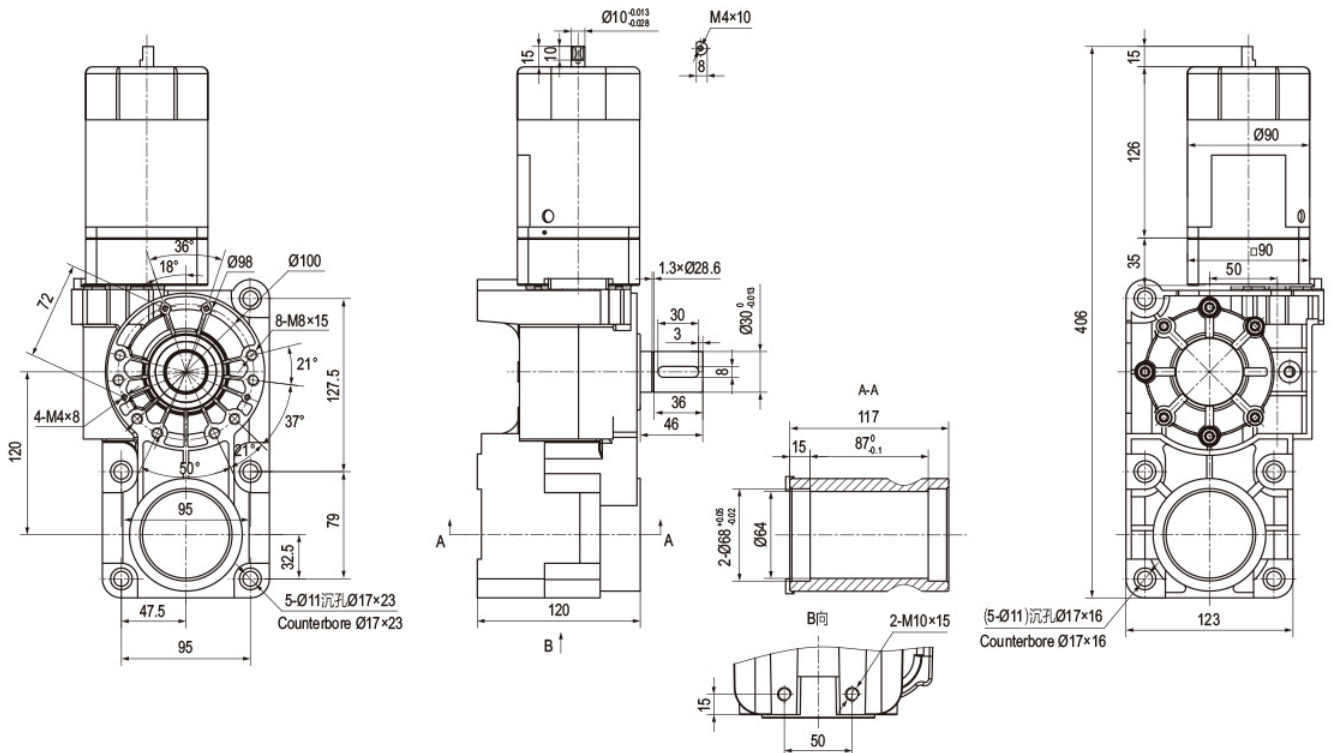

## 无刷直流双减速一体机 Brushless DC Gear Motor

### ■ 特点和应用范围 Features and Scope of Application

无刷电机 24V 安全电机，速度可调，启停平稳，电机效率高，可采用电瓶驱动，减速箱采用专用箱体，预留连杆弹簧机构安装尺寸，一体化设计，主要适用于直杆、折弯杆道闸及车牌识别系统道闸。

Brushless motor 24V safety motor, adjustable speed, stable start and stop, high motor efficiency, can be driven by battery, reducer adopts special box, reserved connecting rod spring mechanism installation size, integrated design, mainly suitable for straight rod, Bending pole barrier and license plate recognition system barrier.

### ■ 无刷直流电机接线 Brushless DC Gear Motor Wiring

端子及接线说明 Terminal and Wiring Instructions							
1	2	3	4	5	6	7	8
U	V	W	GND	Hv	Hw	Hu	Vcc
黄 (粗) Yellow (Thick)	白 (粗) White (Thick)	蓝 (粗) Blue (Thick)	黑 (细) Black (Thin)	白 (细) White (Thin)	蓝 (细) Blue (Thin)	黄 (细) Yellow (Thin)	红 (细) Red (Thin)



### ■ 减速电机基本性能参数 Basic Performance Parameters for Gear Motor

减速电机型号 Motor Item No.	额定功率 Rated Power (W)	额定电压 Rated Voltage (V)	额定电流 Rated Current (A)	额定转速 Rated Sppeed (rpm)	减速比 Ratio	输出扭矩 Output Torque (N.m)	传动效率 Transmission Efficiency	起落杆时间 Lever Time (s)
G4BLD160-24-14S/GRV050UZ-20 × 3.9-90	160	DC24	9.5	1400	78	59.5	70%	1.5
G4BLD160-24-14S/GRV050UZ-40 × 3.9-90	160	DC24	9.5	1400	156	119	70%	3
G4BLD160-24-14S/GRV050UZ-75 × 3.9-90	160	DC24	9.5	1400	156	220	70%	3

### ■ 减速电机尺寸图 External Dimension

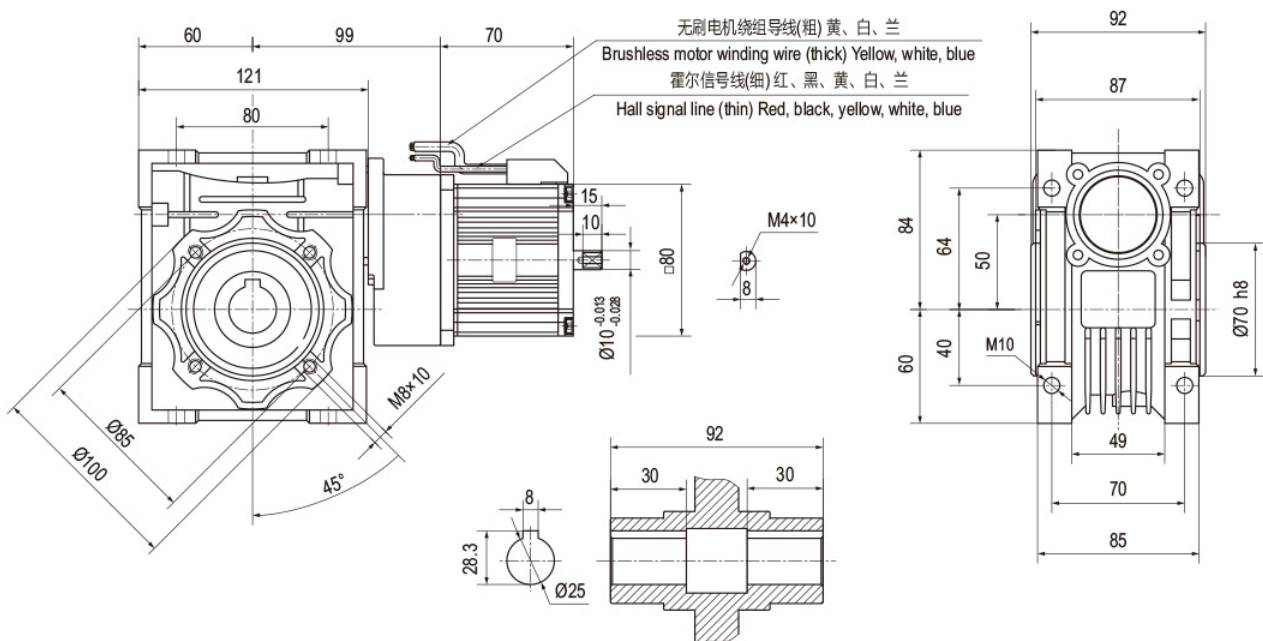

# 普通道闸专用电机

## Normal Barrier Application Gear Motor

### 无刷直流双减速一体机 Brushless DC Gear Motor

#### ■ 特点和应用范围 Features and Scope of Application

无刷电机 24V 安全电机，速度可调，启停平稳，电机效率高，可采用电瓶驱动，减速箱采用专用箱体，预留连杆弹簧机构安装尺寸，一体化设计，主要适用于直杆、折弯杆道闸及车牌识别系统道闸。

Brushless motor 24V safety motor, adjustable speed, stable start and stop, high motor efficiency, can be driven by battery, reducer adopts special box, reserved connecting rod spring mechanism installation size, integrated design, mainly suitable for straight rod, Bending pole barrier and license plate recognition system barrier.

#### ■ 无刷直流电机接线 Brushless DC Gear Motor Wiring

端子及接线说明 Terminal and Wiring Instructions							
1	2	3	4	5	6	7	8
U	V	W	GND	Hv	Hw	Hu	Vcc
黄(粗) Yellow (Thick)	白(粗) White (Thick)	蓝(粗) Blue (Thick)	黑(细) Black (Thin)	白(细) White (Thin)	蓝(细) Blue (Thin)	黄(细) Yellow (Thin)	红(细) Red (Thin)



#### ■ 减速电机基本性能参数 Basic Performance Parameters for Gear Motor

减速电机型号 Motor Item No.	额定功率 Rated Power (W)	额定电压 Rated Voltage (V)	额定电流 Rated Current (A)	额定转速 Rated Spedd (rpm)	减速比 Ratio	输出扭矩 Output Torque (N.m)	传动效率 Transmission Efficiency	起落杆时间 Lever Time (s)
G4BLD160-24-14S/MJ50-GRV050UZ-20 × 3.9-90	160	DC24	9.5	1400	78	59.5	70%	1.5
G4BLD160-24-14S/MJ50-GRV050UZ-40 × 3.9-90	160	DC24	9.5	1400	156	119	70%	3
G4BLD160-24-14S/MJ50-GRV050UZ-75 × 3.9-90	160	DC24	9.5	1400	156	220	70%	6

#### ■ 减速电机尺寸图 External Dimension

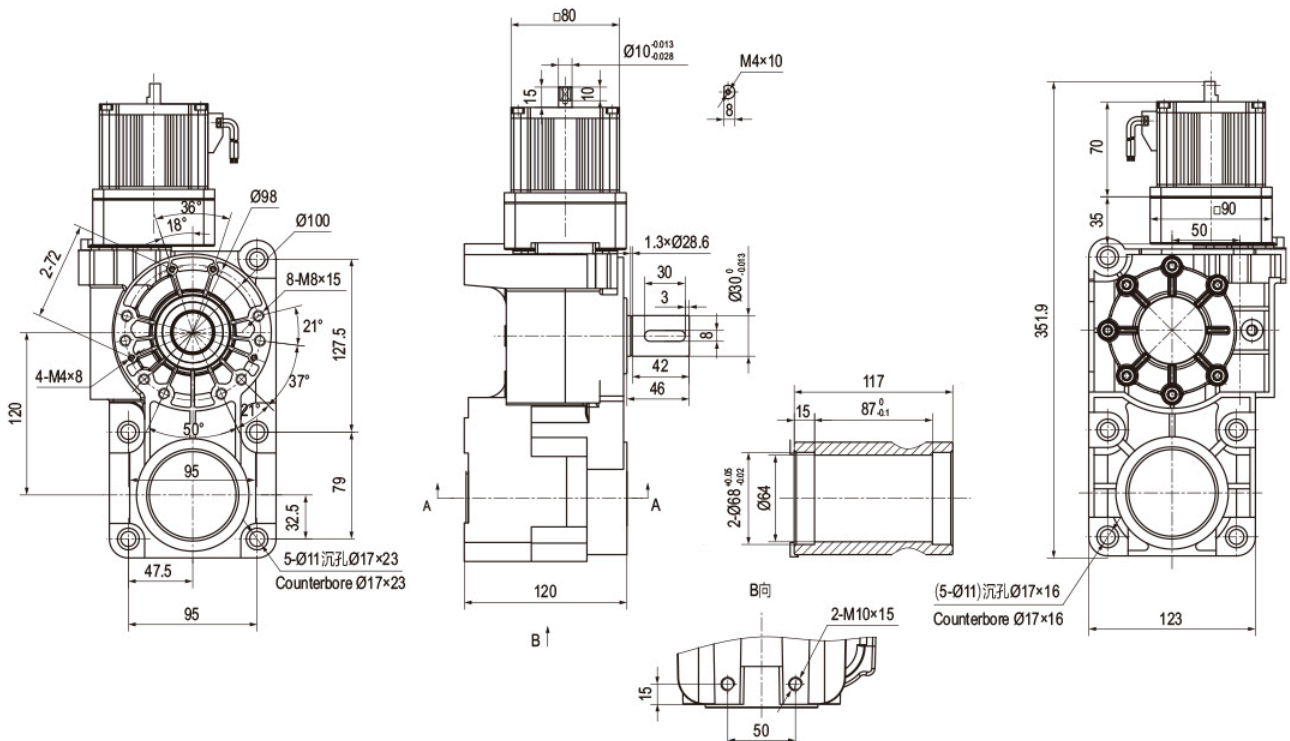



## 无刷直流平行齿减速电机 Brushless DC Parallel Gear Motor

### ■ 特点和应用范围 Features and Scope of Application

无刷电机 24V 安全电机，速度可调，启停平稳，电机效率高，可采用电瓶驱动，减速箱采用专用箱体，预留连杆弹簧机构安装尺寸，一体化设计，主要适用于直杆、折弯杆道闸及车牌识别系统道闸，高速公路道闸。

Brushless motor 24V safety motor, adjustable speed, stable start and stop, high motor efficiency, can be driven by battery, reducer adopts special box, reserved connecting rod spring mechanism installation size, integrated design, mainly suitable for straight rod, Bending pole barriers and license plate recognition system barriers, highway barriers.



### ■ 无刷直流电机接线 Brushless DC Gear Motor Wiring

端子及接线说明 Terminal and Wiring Instructions							
1	2	3	4	5	6	7	8
U	V	W	GND	Hv	Hw	Hu	Vcc
黄(粗) Yellow (Thick)	白(粗) White (Thick)	蓝(粗) Blue (Thick)	黑(细) Black (Thin)	白(细) White (Thin)	蓝(细) Blue (Thin)	黄(细) Yellow (Thin)	红(细) Red (Thin)

### ■ 减速电机基本性能参数 Basic Performance Parameters for Gear Motor

减速电机型号 Motor Item No.	额定功率 Rated Power (W)	额定电压 Rated Voltage (V)	额定电流 Rated Current (A)	额定转速 Rated Spd (rpm)	减速比 Ratio	输出扭矩 Output Torque (N.m)	传动效率 Transmission Efficiency	起落杆时间 Lever Time (s)
MJ37B-160-50S	160	DC24	9.5	1400	50	46.3	85%	0.9
MJ37B-160-75S	160	DC24	9.5	1400	75	69.5	85%	1.5
MJ37B-160-150S	160	DC24	9.5	1400	150	139	85%	3

### ■ 减速电机尺寸图 External Dimension

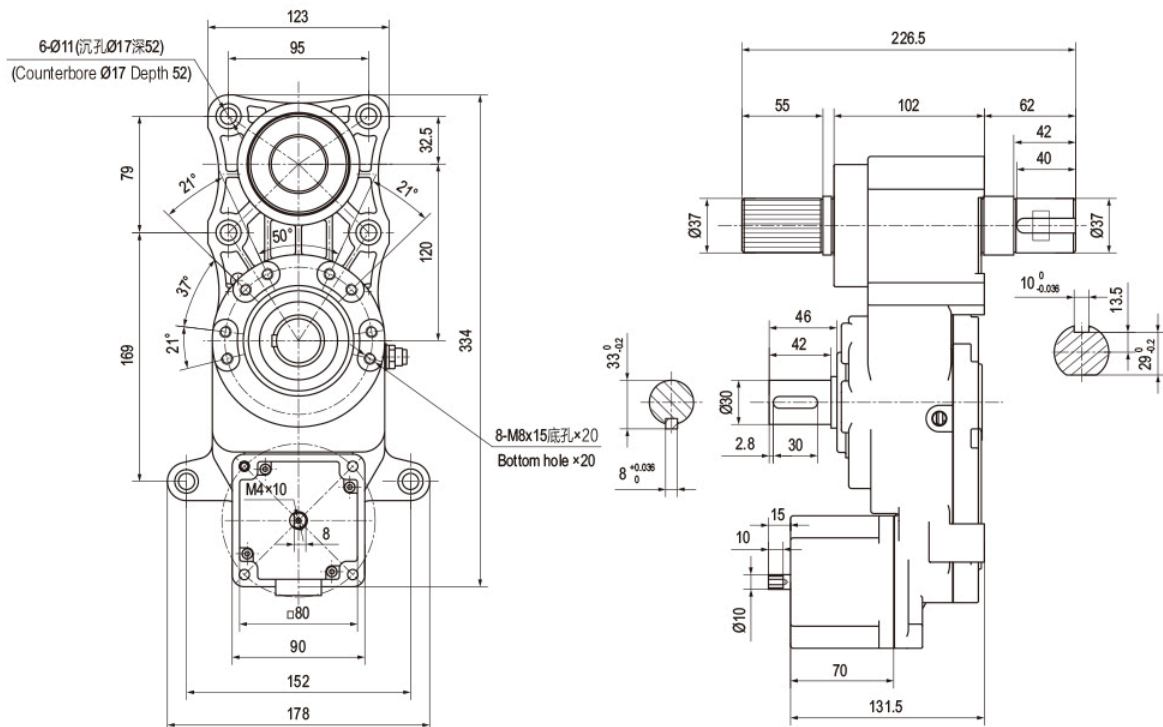

### 无刷直行星齿减速电机 Brushless DC Planetary Gear Motor

#### ■ 特点和应用范围 Features and Scope of Application

无刷电机 24V 安全电机，速度可调，启停平稳，电机效率高，可采用电瓶驱动，减速箱行星齿轮传动结构，体积小，承载能力大，主要适用于直杆、折弯杆道闸及车牌识别系统道闸，高速公路道闸。

Brushless motor 24V safety motor, adjustable speed, stable start and stop, high motor efficiency, battery drive, planetary gear transmission structure of reduction box, small size, large carrying capacity, mainly suitable for straight pole, bending pole gate and License plate recognition system barriers, highway barriers.

#### ■ 无刷直流电机接线 Brushless DC Gear Motor Wiring

端子及接线说明 Terminal and Wiring Instructions							
1	2	3	4	5	6	7	8
U	V	W	GND	Hv	Hw	Hu	Vcc
黄 (粗) Yellow (Thick)	白 (粗) White (Thick)	蓝 (粗) Blue (Thick)	黑 (细) Black (Thin)	白 (细) White (Thin)	蓝 (细) Blue (Thin)	黄 (细) Yellow (Thin)	红 (细) Red (Thin)



#### ■ 减速电机基本性能参数 Basic Performance Parameters for Gear Motor

减速电机型号 Motor Item No.	额定功率 Rated Power (W)	额定电压 Rated Voltage (V)	额定电流 Rated Current (A)	额定转速 Rated Speed (rpm)	减速比 Ratio	输出扭矩 Output Torque (N.m)	传动效率 Transmission Efficiency
G2BLD120-24-30S/GPE60-64	120	DC24	6.0	3000	64	18.3	90%

#### ■ 减速电机尺寸图 External Dimension

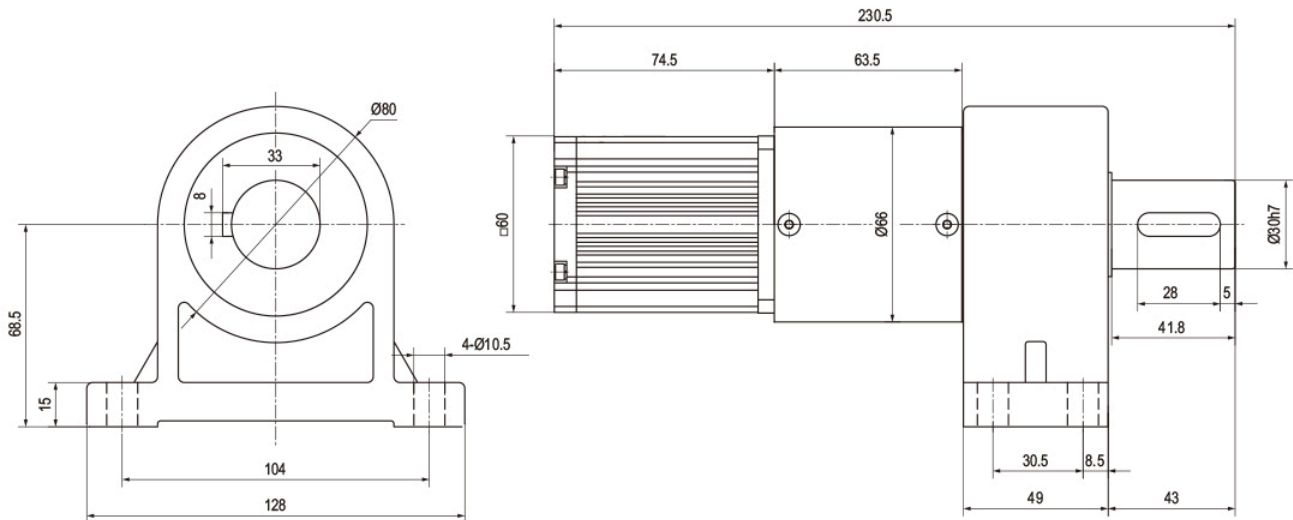

## 单相交流双减速一体机 Single Phase AC Gear Motor

### ■ 特点和应用范围 Features and Scope of Application

蜗轮采用锡青铜材料，更加耐磨，主要适用于广告道闸，空降道闸。

The worm wheel is made of tin bronze material, which is more wear-resistant. It is mainly suitable for advertising barriers and airborne barriers.



### ■ 单相齿轮减速马达接线图 Single-phase Gear Motor Wiring Diagram

正转 Clockwise

反转 Count-clockwise

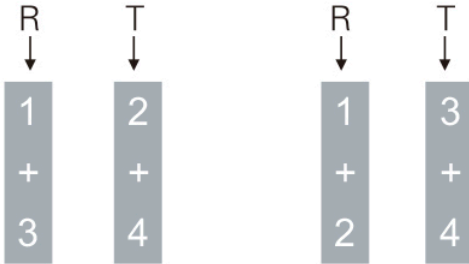

### ■ 减速电机基本性能参数 Basic Performance Parameters for Gear Motor

减速电机型号 Motor Item No.	额定功率 Rated Power (W)	额定频率 Rated Frequency (Hz)	额定电压 Rated Voltage (V)	额定电流 Rated Current (A)	额定转速 Rated Speed (rpm)	电容 Capacitor ( $\mu$ F)	减速比 Ratio	输出扭矩 Output Torque (N.m)	传动效率 Transmission Efficiency	起落杆 时间 Lever Time (s)
Y18-200A-F-C/GRV063UZ-50 × 5-18T	200	50	单相 Single Phase AC110	4.0	1400	40	250	230	70%	5
Y18-200A-F-C/GRV063UZ-60 × 5-18T	200	50		4.0	1400	40	300	280	70%	6

### ■ 减速电机尺寸图 External Dimension

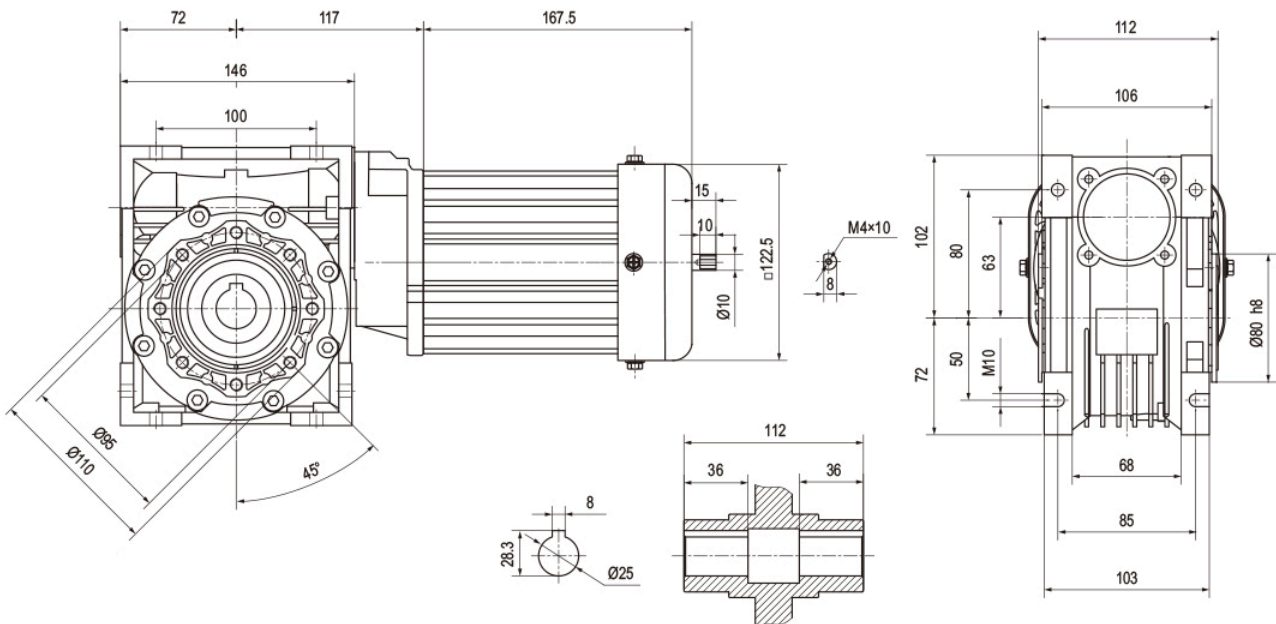

### 三相交流双减速一体机 Three Phase AC Gear Motor

#### ■ 特点和应用范围 Features and Scope of Application

交流变频电机速度可调，启停平稳、对减速箱冲击较小，蜗轮采用锡青铜材料，更加耐磨，主要适用于广告道闸，空降道闸。

The speed of the AC variable frequency motor is adjustable, starts and stops smoothly, and has less impact on the gearbox. The worm wheel is made of tin bronze material, which is more wear-resistant. It is mainly suitable for advertising barriers and airborne barriers.

#### ■ 电机接线图 Motor Wiring Diagram

三相AC220V接线图  
Three-phase AC220V Wiring Diagrams

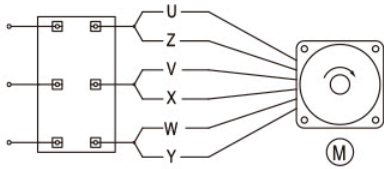

三相AC380V接线图  
Three-phase AC380V Wiring Diagrams

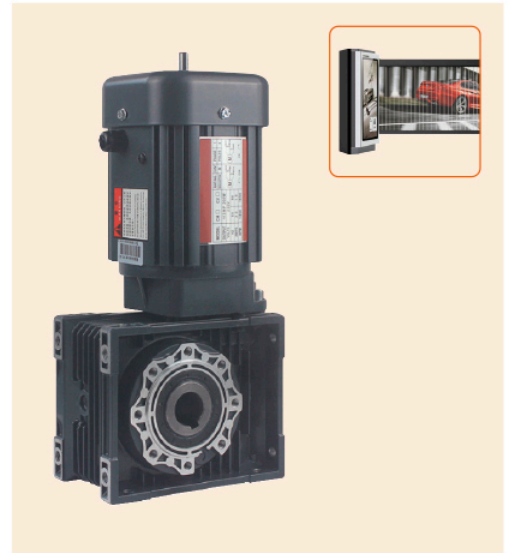
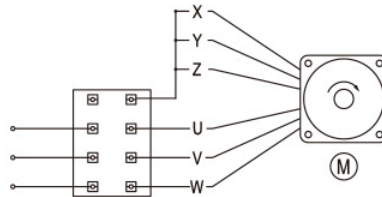

#### ■ 减速电机基本性能参数 Basic Performance Parameters for Gear Motor

减速电机型号 Motor Item No.	额定功率 Rated Power (W)	额定频率 Rated Frequency (Hz)	额定电压 Rated Voltage (V)	额定电流 Rated Current (A)	额定转速 Rated Speed (rpm)	减速比 Ratio	输出扭矩 Output Torque (N.m)	传动效率 Transmission Efficiency	起落杆时间 Lever Time (s)
Y18-200S-F-C/GRV063UZ-50 × 5-18T	200	50	三相 Three Phase AC220	1.4	1410	250	230	70%	5
Y18-200S-F-C/GRV063UZ-60 × 5-18T	200	50		1.4	1410	300	280	70%	6

#### ■ 减速电机尺寸图 External Dimension

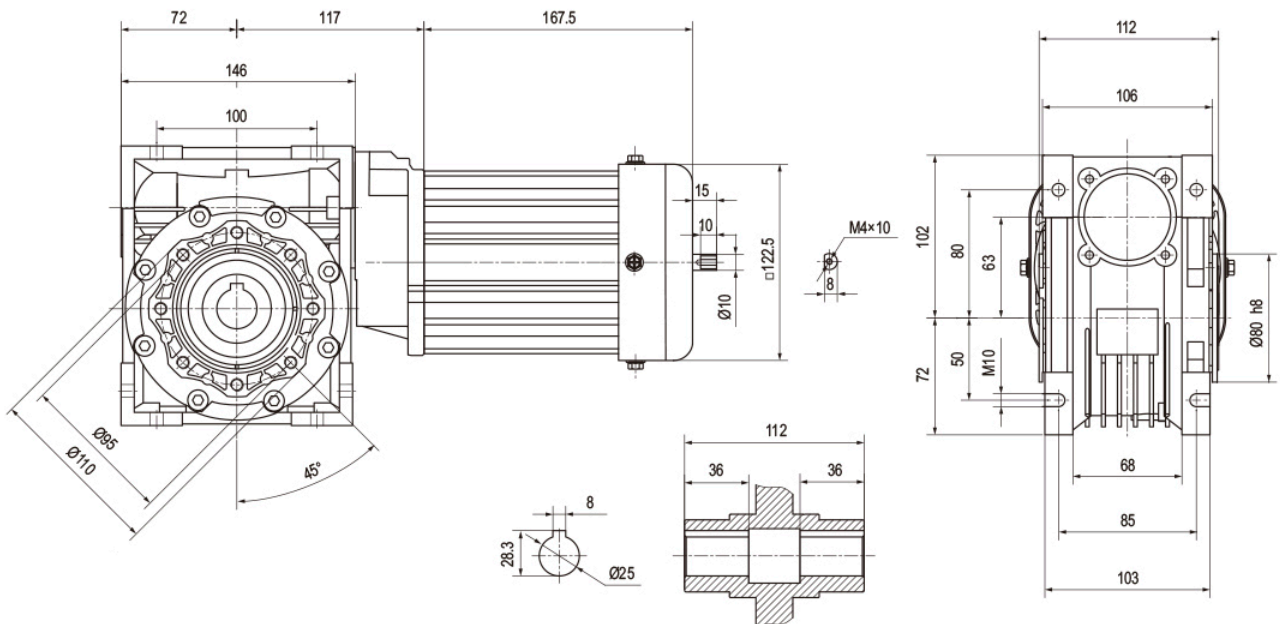

## 无刷直流双减速一体机 Brushless DC Gear Motor

### ■ 特点和应用范围 Features and Scope of Application

无刷电机 24V 安全电机，速度可调，启停平稳，电机效率高，可采用电瓶驱动，蜗轮采用锡青铜材料，更加耐磨，主要适用于广告道闸，空降道闸。

Brushless motor 24V safety motor, adjustable speed, stable start and stop, high motor efficiency, battery drive, worm wheel made of tin bronze material, more wear-resistant, mainly suitable for advertising barriers, airborne barriers.

### ■ 无刷直流电机接线 Brushless DC Gear Motor Wiring

端子及接线说明 Terminal and Wiring Instructions							
1	2	3	4	5	6	7	8
U	V	W	GND	Hv	Hw	Hu	Vcc
黄 (粗) Yellow (Thick)	白 (粗) White (Thick)	蓝 (粗) Blue (Thick)	黑 (细) Black (Thin)	白 (细) White (Thin)	蓝 (细) Blue (Thin)	黄 (细) Yellow (Thin)	红 (细) Red (Thin)



### ■ 减速电机基本性能参数 Basic Performance Parameters for Gear Motor

减速电机型号 Motor Item No.	额定功率 Rated Power (W)	额定电压 Rated Voltage (V)	额定电流 Rated Current (A)	额定转速 Rated Sppeed (rpm)	减速比 Ratio	输出扭矩 Output Torque (N.m)	传动效率 Transmission Efficiency	起落杆时间 Lever Time (s)
G5BLD200-24-14S/GRV063UZ-30 × 5-90	200	DC24	12.0	1400	150	140	70%	3
G5BLD200-24-14S/GRV063UZ-40 × 5-90	200	DC24	12.0	1400	200	185	70%	5

### ■ 减速电机尺寸图 External Dimension

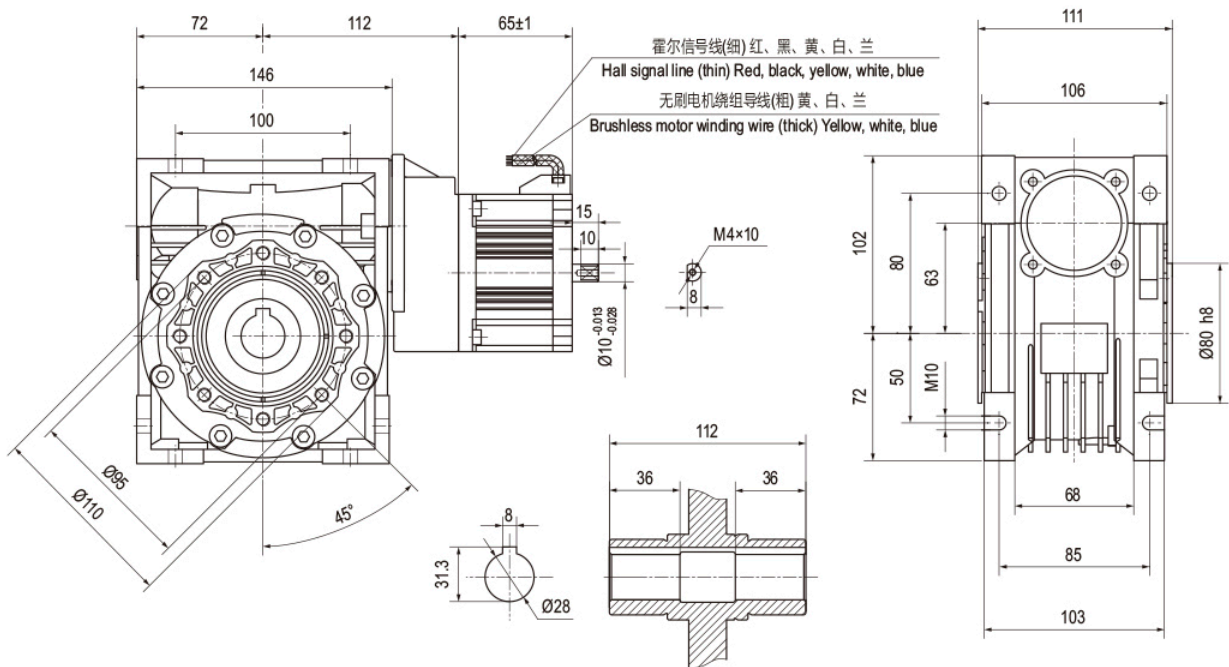

### 无刷直流平行齿减速电机 Brushless DC Parallel Gear Motor

#### ■ 特点和应用范围 Features and Scope of Application

无刷电机 24V 安全电机，速度可调，启停平稳，电机效率高，可采用电瓶驱动，减速箱采用专用箱体，预留连杆弹簧机构安装尺寸，一体化设计，主要适用于直杆、折弯杆道闸及车牌识别系统广告道闸。

Brushless motor 24V safety motor, adjustable speed, stable start and stop, high efficiency of the motor, can be driven by a battery, the gearbox adopts a special box, reserved connecting rod spring mechanism installation size, integrated design, mainly suitable for straight rods, Bending pole barrier and advertising barrier for license plate recognition system.

#### ■ 无刷直流电机接线 Brushless DC Gear Motor Wiring

端子及接线说明 Terminal and Wiring Instructions							
1	2	3	4	5	6	7	8
U	V	W	GND	Hv	Hw	Hu	Vcc
黄 (粗) Yellow (Thick)	白 (粗) White (Thick)	蓝 (粗) Blue (Thick)	黑 (细) Black (Thin)	白 (细) White (Thin)	蓝 (细) Blue (Thin)	黄 (细) Yellow (Thin)	红 (细) Red (Thin)

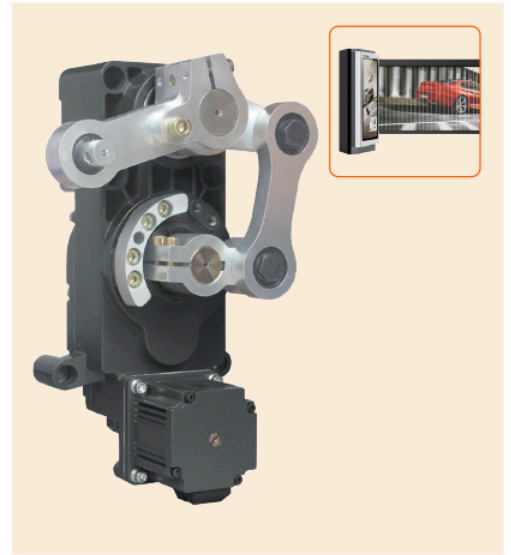

#### ■ 减速电机基本性能参数 Basic Performance Parameters for Gear Motor

减速电机型号 Motor Item No.	额定功率 Rated Power (W)	额定电压 Rated Voltage (V)	额定电流 Rated Current (A)	额定转速 Rated Spedd (rpm)	减速比 Ratio	输出扭矩 Output Torque (N.m)	传动效率 Transmission Efficiency	起落杆时间 Lever Time (s)
MJ37A-200-150S	200	DC24	11.9	1400	150	185	85%	3

#### ■ 减速电机尺寸图 External Dimension

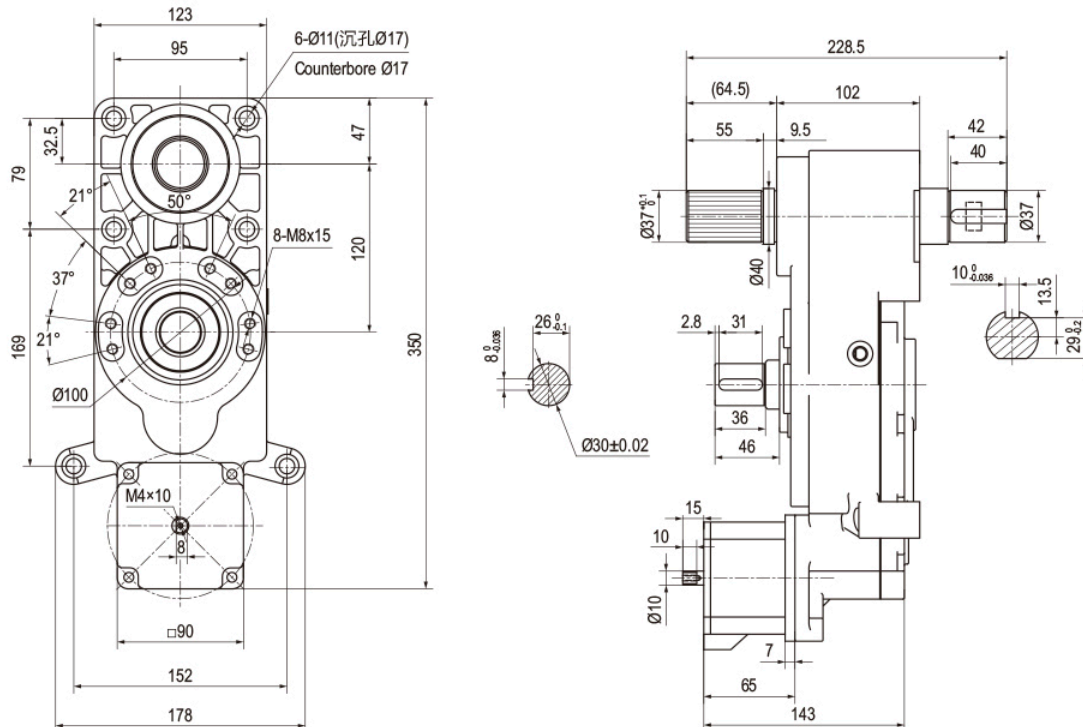

### 单相交流双减速一体机 Single Phase AC Gear Motor

#### ■ 特点和应用范围 Features and Scope of Application

蜗轮采用锡青铜材料，更加耐磨，主要适用于广告道闸，空降道闸。

The worm wheel is made of tin bronze material, which is more wear-resistant. It is mainly suitable for advertising barriers and airborne barriers.



#### ■ 单相齿轮减速马达接线图 Single-phase Gear Motor Wiring Diagram

正转 Clockwise

反转 Count-clockwise

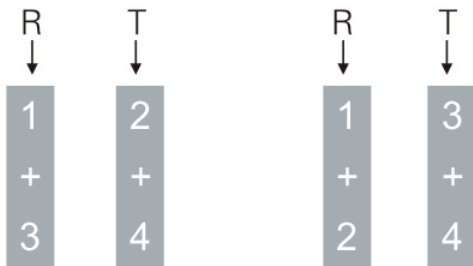

#### ■ 减速电机基本性能参数 Basic Performance Parameters for Gear Motor

减速电机型号 Motor Item No.	额定功率 Rated Power (W)	额定频率 Rated Frequency (Hz)	额定电压 Rated Voltage (V)	额定电流 Rated Current (A)	额定转速 Rated Speed (rpm)	电容 Capacitor (μF)	减速比 Ratio	输出扭矩 Output Torque (N.m)	传动效率 Transmission Efficiency	起落杆 时间 Lever Time (s)
Y18-200A-F-C/GRV063UZ-60 × 5-18T	200	50	单相 Single Phase AC110	4.0	1400	40	300	280	70%	6
Y18-200A-F-C/GRV063UZ-60 × 7.5-18T	200	50		4.0	1400	40	450	420	70%	9

#### ■ 减速电机尺寸图 External Dimension

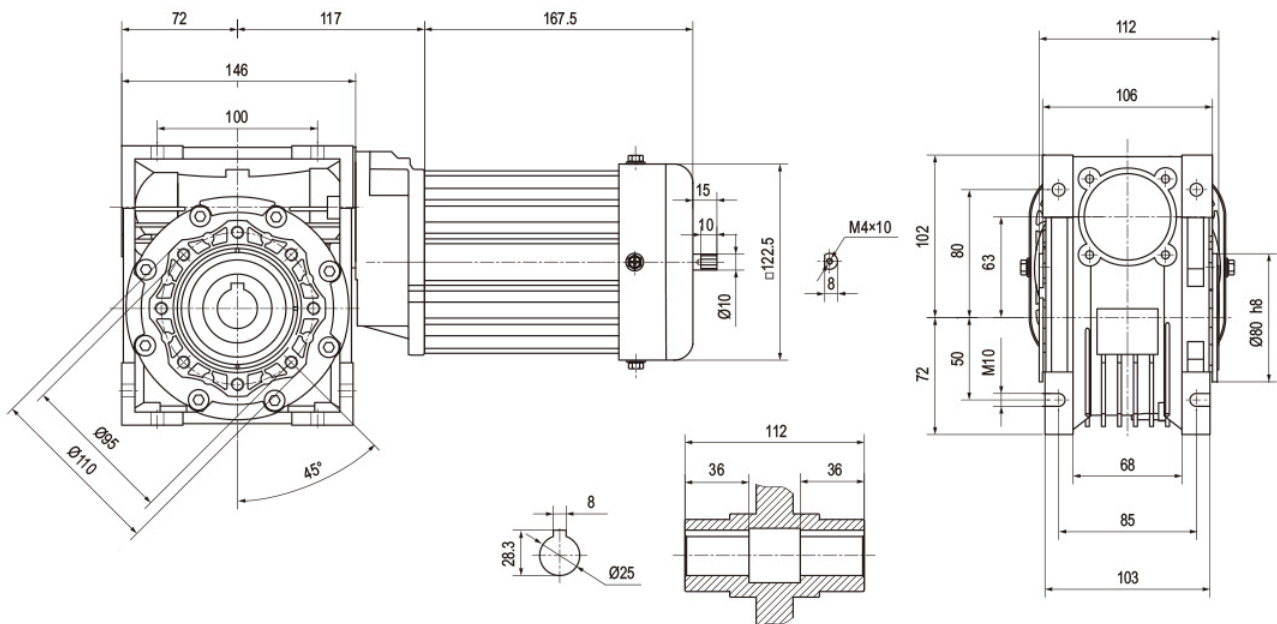

# 空降道闸专用电机

## Airborne Barrier Application Gear Motor

### 单相交流双减速一体机 Single Phase AC Gear Motor

#### ■ 特点和应用范围 Features and Scope of Application

蜗轮采用锡青铜材料，更加耐磨，大减速比，主要适用于广告道闸，空降道闸。

The worm wheel is made of tin bronze material, which is more wear-resistant, big reduction ratio. It is mainly suitable for advertising barriers and airborne barriers.



#### ■ 单相齿轮减速马达接线图 Single-phase Gear Motor Wiring Diagram

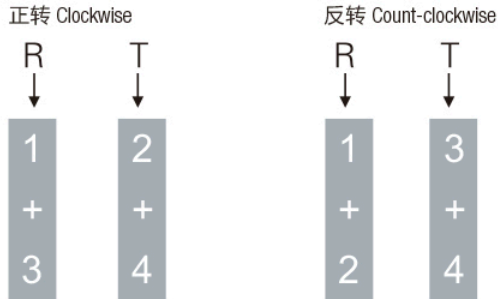

#### ■ 减速电机基本性能参数 Basic Performance Parameters for Gear Motor

减速电机型号 Motor Item No.	额定功率 Rated Power (W)	额定频率 Rated Frequency (Hz)	额定电压 Rated Voltage (V)	额定电流 Rated Current (A)	额定转速 Rated Speed (rpm)	电容 Capacitor (μF)	减速比 Ratio	输出扭矩 Output Torque (N.m)	传动效率 Transmission Efficiency	起落杆 时间 Lever Time (s)
Y18-250C-F-C/GRV075UZ-60 × 5-18T	250	50	单相 Single Phase AC220	2.5	1410	12	300	350	70%	6
Y18-250C-F-C/GRV075UZ-60 × 7.5-18T	250	50		2.5	1410	12	450	525	70%	9

#### ■ 减速电机尺寸图 External Dimension

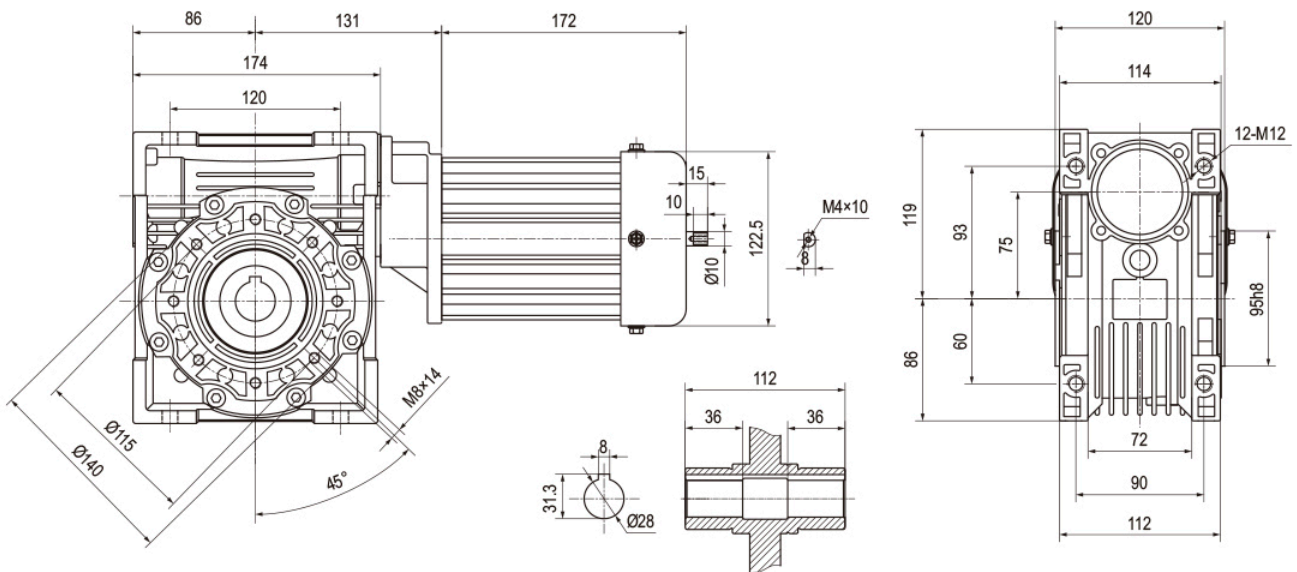



### 三相交流双减速一体机 Three Phase AC Gear Motor

#### ■ 特点和应用范围 Features and Scope of Application

交流变频电机速度可调，启停平稳、对减速箱冲击较小，蜗轮采用锡青铜材料，更加耐磨，大减速比，主要适用于空降道闸。

The speed of the AC variable frequency motor is adjustable, starts and stops smoothly, and has less impact on the gearbox. The worm wheel is made of tin bronze material, which is more wear-resistant. It is mainly suitable for airborne barriers.

#### ■ 电机接线图 Motor Wiring Diagram

三相AC220V接线图  
Three-phase AC220V Wiring Diagrams

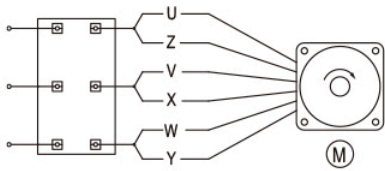

三相AC380V接线图  
Three-phase AC380V Wiring Diagrams

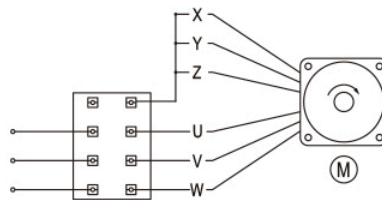

#### ■ 减速电机基本性能参数 Basic Performance Parameters for Gear Motor

减速电机型号 Motor Item No.	额定功率 Rated Power (W)	额定频率 Rated Frequency (Hz)	额定电压 Rated Voltage (V)	额定电流 Rated Current (A)	额定转速 Rated Speed (rpm)	减速比 Ratio	输出扭矩 Output Torque (N.m)	传动效率 Transmission Efficiency	起落杆 时间 Lever Time (s)
Y18-200S-F-C/GRV063UZ-60 × 5-18T	200	50	三相 Three Phase AC220	1.4	1410	300	280	70%	6
Y18-200S-F-C/GRV063UZ-60 × 7.5-18T	200	50		1.4	1410	450	420	70%	9

#### ■ 减速电机尺寸图 External Dimension

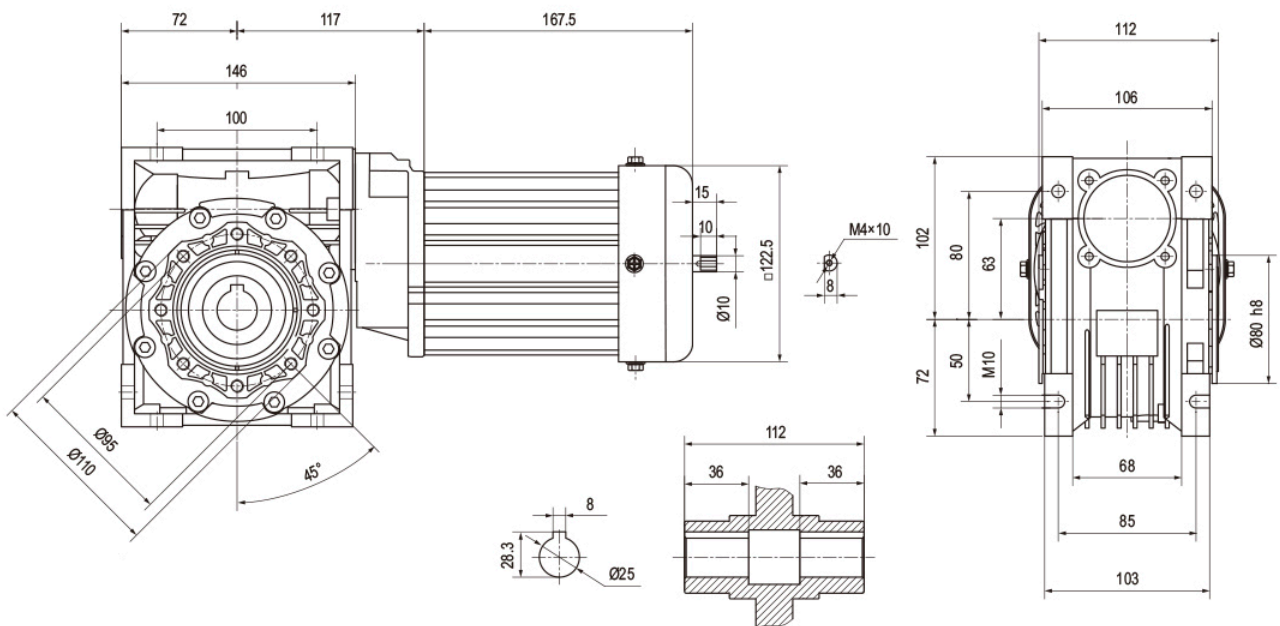

# 空降道闸专用电机

## Airborne Barrier Application Gear Motor

### 三相交流双减速一体机 Three Phase AC Gear Motor

#### ■ 特点和应用范围 Features and Scope of Application

交流变频电机速度可调，启停平稳、对减速箱冲击较小，蜗轮采用锡青铜材料，更加耐磨，大减速比，主要适用于空降道闸。

The speed of the AC variable frequency motor is adjustable, starts and stops smoothly, and has less impact on the gearbox. The worm wheel is made of tin bronze material, which is more wear-resistant. It is mainly suitable for airborne barriers.

#### ■ 电机接线图 Motor Wiring Diagram

三相AC220V接线图  
Three-phase AC220V Wiring Diagrams

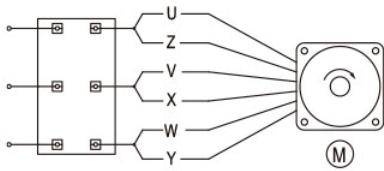

三相AC380V接线图  
Three-phase AC380V Wiring Diagrams

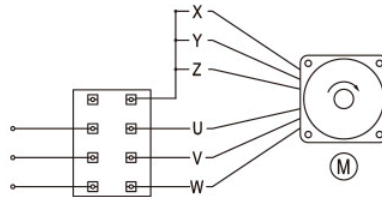

#### ■ 减速电机基本性能参数 Basic Performance Parameters for Gear Motor

减速电机型号 Motor Item No.	额定功率 Rated Power (W)	额定频率 Rated Frequency (Hz)	额定电压 Rated Voltage (V)	额定电流 Rated Current (A)	额定转速 Rated Speed (rpm)	减速比 Ratio	输出扭矩 Output Torque (N.m)	传动效率 Transmission Efficiency	起落杆 时间 Lever Time (s)
Y18-250S-F-C/GRV063UZ-60 × 5-18T	250	50	三相 Three Phase AC220	1.45	1410	300	350	70%	6
Y18-250S-F-C/GRV063UZ-60 × 7.5-18T	250	50		1.45	1410	450	525	70%	9

#### ■ 减速电机尺寸图 External Dimension

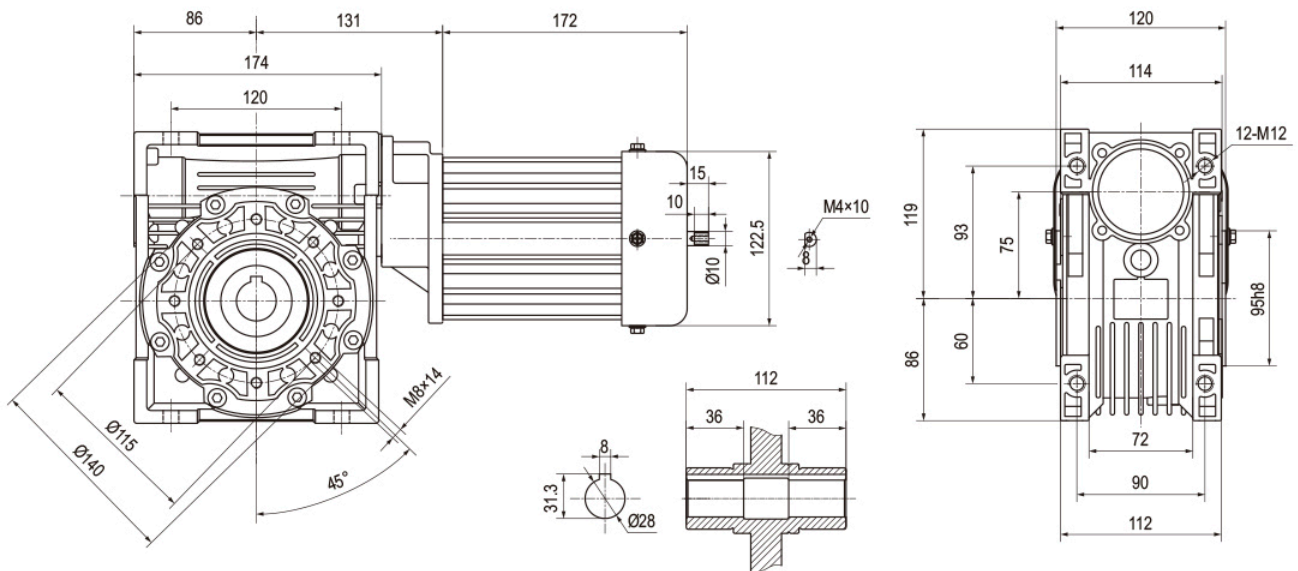



**满足您的需求是我们的宗旨——**  
**Meeting your needs is our aim**

台邦集团公司产品广泛应用于各种工业流水线、智能装备、精密传动、印刷机械、纺织机械、仪器仪表、食品机械、输变电设备、道闸门机、医疗设备、物流设备、安检设施、金融设备、新能源以及工业机器人等行业，是自动化设备首选的配套产品。

Taibang Group's products are widely used in various industrial assembly lines, intelligent equipment, precision transmission, printing machinery, textile machinery, instrumentation, food machinery, power transmission and transformation equipment, barriers, medical equipment, logistics facilities, financial equipment, new energy, industrial robots and other industries are the first-choice supporting products for automation equipment.

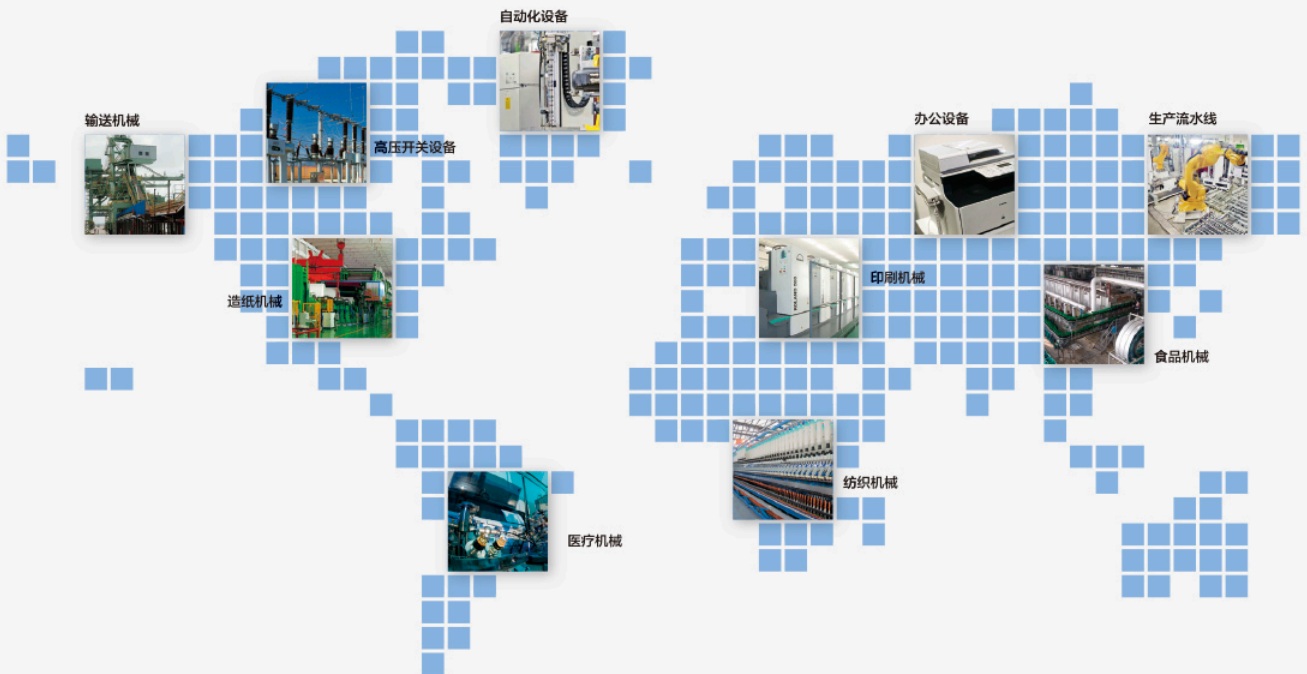

## 台邦电机工业集团有限公司

总部：浙江省乐清经济开发区纬十六路 216 号  
电话：0577-57155003 57120800  
海外销售事业部：+86-577-62661869  
邮箱：tb@gpgmotor.com  
网址：//www.gpgmotor.com

### 台邦集团北京销售事业部

地址：北京市丰台科技园海鹰路 6 号院 25 楼西区  
电话：010-83618811 63767077 63767090  
传真：010-63767660

### 台邦集团上海销售事业部

地址：上海市闵行区都会路 2338 号 78 栋 (总部 1 号)  
电话：021-33502002 33589990  
传真：021-33502225

### 台邦集团广东销售事业部

地址：广东省东莞市厚街镇南环路涌口新兴街 8 号  
电话：0769-82682666 88030057  
传真：0769-85756166

### 台邦集团天津销售事业部

地址：天津市津南区双港科技园慧科路与睿平道交口坤港产业园 37 号楼  
电话：022-27606038  
传真：022-27606038

### 台邦集团福建销售事业部

地址：福建省晋江市磁灶镇海峡国际五金机电城 3 期 8 栋 110-111 号  
电话：0595-85350011 22306661  
传真：0595-22306667

### 台邦集团江苏销售事业部

地址：江苏省苏州市相城区渭塘镇爱格豪路 18 号二楼  
电话：0512-69592758 65085552  
传真：0512-69576661

### 台邦集团浙江销售事业部

地址：浙江省乐清经济开发区纬十六路 216 号  
电话：0577-62661818 62661811  
传真：0577-62661886

## Taibang Motor Industrial Group Co., Ltd.

Headquarters: No. 216, Weishilu Road,  
Yueqing Economic Development Zone, Zhejiang Province  
TEL: 0577-57155003 57120800  
International Business Department: +86-577-62661869  
E-mail: tb@gpgmotor.com  
URL: Http: //www.gpgmotor.com

### Taibang Group Beijing Sales Department

ADD: West District, 25th Floor, Yard 6, Haiying Road,  
Fengtai Science and Technology Park, Beijing  
TEL: 010-83618811 63767077 63767090  
FAX: 010-63767660

### Taibang Group Shanghai Sales Department

ADD: Building 78, No. 2338, Duhui Road, Minhang District,  
Shanghai (Headquarters No. 1)  
TEL: 021-33502002 33589990  
FAX: 021-33502225

### Taibang Group Guangdong Sales Department

ADD: No. 8, Xinxing Street, Yongkou, Nanhuan Road, Houjie Town,  
Dongguan City, Guangdong Province  
TEL: 0769-82682666 88030057  
FAX: 0769-85756166

### Taibang Group Tianjin Sales Department

ADD: Building 37, Kungang Industrial Park, Intersection of Huike Road and  
Ruiping Road, Shuanggang Science park, Jinnan District, Tianjin  
TEL: 022-27606038  
FAX: 022-27606038

### Taibang Group Fujian Sales Department

No.110-111, Building 8, Phase 3, Haixia International Hardware and  
Electrical City, Magizao Town, Jinjiang City, Fujian Province  
TEL: 0595-85350011 22306661  
FAX: 0595-22306667

### Taibang Group Jiangsu Sales Department

ADD: 2nd Floor, No. 18, Aigehao Road, Weitang Town,  
Xiangcheng District, Suzhou City, Jiangsu Province  
TEL: 0512-69592758 65085552  
FAX: 0512-69576661

### Taibang Group Zhejiang Sales Department

ADD: No. 216, Weishilu Road,  
Yueqing Economic Development Zone, Zhejiang Province  
TEL: 0577-62661818 62661811  
FAX: 0577-62661886